

Wireless Sensor System for Airborne Applications

Steve Pellarin

Teletronics Technology Corporation

Steven Musteric

46th Test Systems Squadron

Eglin Air Force Base, FL

Abstract

Adding an instrumentation / telemetry system to a test article has historically required an intrusive installation. Power, wiring, and available space typically present significant challenges. There has been a long-standing need in the test and training community for a non-intrusive, flexible and modular instrumentation and telemetry system that can be installed on an aircraft or other test article without the need for permanent modifications. In addition, as available space in aircraft weapon bays, small weapons, and unmanned vehicles becomes a premium, the miniaturization of remote sensors and telemetry units becomes critical.

This paper describes the current status of the Advanced Subminiature Telemetry System (ASMT) Initial Test Capability Project. It discusses the challenges that have been overcome in developing a wireless sensor network system for use in an airborne test environment. These include wireless sensor packaging design, selection of operating frequencies, COTS wireless devices, batteries, system synchronization and data bandwidth calculations. The paper will also document the progress to date including preliminary test results.

Key Words

Network, Miniaturized, Non-Intrusive, Wireless sensor, Bluetooth, Zigbee, IEEE 802.15.4, Data Acquisition

Introduction

Flight test vehicles require a certain degree of wiring and installation modification to accommodate flight test equipment. In most cases this equipment is used either in a test vehicle dedicated for flight test, or in production vehicle to solve a problem or test a new system. When a dedicated test vehicle is used, it is expected that the installation of test equipment will require a high degree of intrusiveness. The use of an instrumentation system in a production vehicle imposes on the instrumentation engineer to minimize wiring and modification. A small inexpensive network based instrumentation/telemetry system that can be non-intrusively installed in a variety of configurations and locations

on a test vehicle without significantly impacting the performance of the system being tested has been the goal of the ASMT project and instrumentation engineers. The implementation of a complete non-intrusive flight test system is both difficult and beyond the scope of this paper. The possible use of a sub-system acquiring data from several wireless sensors with minimal intrusiveness is both worth investigating and achievable. This paper will discuss the challenges and barriers that require in depth study and test in order to implement and use such a system on a test vehicle. The design of a wireless sensor to be installed on the skin of a test vehicle poses challenges that are far beyond a simple data acquisition design. We will evaluate the challenge, the decision making process, and the possible direction to be taken for realizing a successful wireless sensor design for airborne flight test applications.

System Overview

The system is comprised of a group of wireless sensors for data acquisition that communicate with an on-board data system. The system includes wireless sensor units with separate installation, and a wireless control unit residing within the data system that collects data from the network of wireless sensors. See Figure 1 for the system diagram.

Figure 1. Wireless sensor system diagram

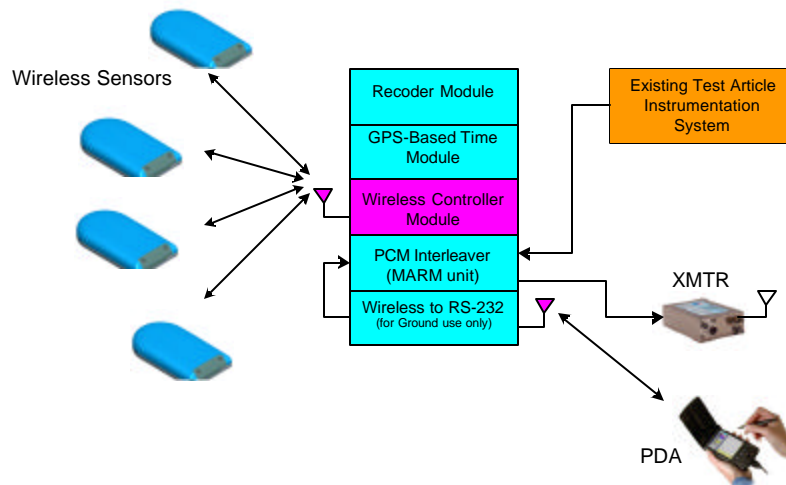

The wireless sensor incorporates transducers, signal conditioning, an acquisition controller, a processor, power (battery), a wireless radio, and an antenna into a sealed, aerodynamically shaped, miniaturized package. It is intended for external installation on a test vehicle via the use of an electro-cleavable adhesive.

For some applications, a wireless sensor unit may require an external transducer and an external antenna installation. In this application, the only element installed on the skin of the test vehicle is the antenna. This application requires the use of available power near the sensor unit location, which eliminates the need of a battery. This is very useful in the

case where instrumentation is installed within a pod and data is transmitted back to the fuselage of the aircraft.

The wireless control unit is part of the on-board data system for controlling and collecting data from the wireless sensors. The control unit provides a self-discovery mechanism for identifying the sensors in its network, facilitating the sensor calibration process, programming acquisition variables in the sensor units, and providing two way communication with all the sensors in its network. The installation of the controlling unit as part of the data system may require an external remote antenna for communication with the wireless sensors.

As an added complexity, the system allows for multiple wireless control units within an on-board data system. Each control unit communicates with its network of wireless sensors for control and data.

The paper will describe in detail three types of modules currently being developed under the ASMT Initial Test Capability Project. The three types of units being developed are:

- Wireless sensor unit with integrated transducer and battery
- Wireless sensor unit with external transducer and uses external 28 VDC power
- Wireless control unit

Wireless Sensor Unit with Integrated Transducer and Battery

This wireless sensor node is a stand-alone assembly installed externally on the skin of the test article. It contains a single tri-axial accelerometer and conditions, digitizes and encodes the data for wireless transmission to the collector node. The sensor node is processor based and allows user programmable control of sensor variables and data filtering. The sensor programmable variables include channel sample rate, gain, offset, and filter cutoff frequency characteristics. All calibration and signal conditioning will be preset within the unit. The sensor node is fully programmable via the wireless connection from the controller node. The unit operates from a single replaceable internal battery for up to four hours. It includes an on-board non-volatile memory for storage of critical information such as module identifier, channel setup, transducer calibration data, etc. An IEEE-1451.0 “like” Transducer Electronic Data Sheet (TEDS) datasheet is employed. See Figure 2.

Figure 2. Wireless Sensor unit with built-in transducer

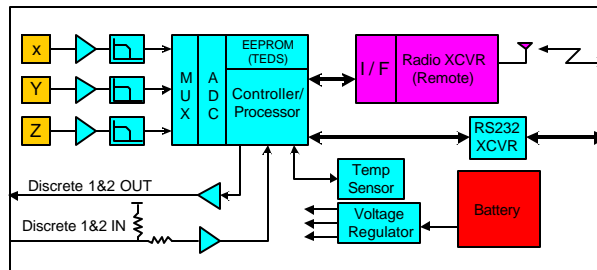

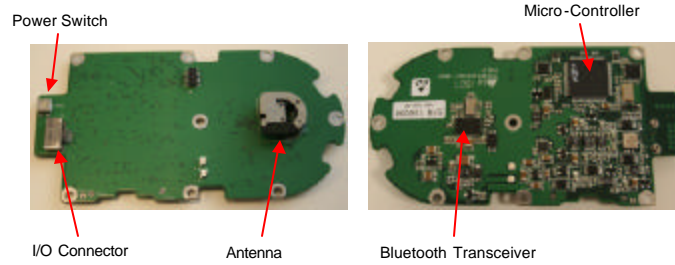

The internal triaxial accelerometer is optimized for measuring low frequency vibration response. The sensor allows a programmable sample rate of up to 200 samples/sec, and has a programmable filter whose -3dB frequency is automatically set to $\frac{1}{4}$ of the sample rate (1 Hz to 50 Hz). The channel filter has a 6-pole Butterworth IIR characteristic. A 5-pole Butterworth anti-aliasing filter with a -3dB frequency of 75 Hz precedes the A/D converter. This, along with the over-sampling scheme of the A/D converter, prevents aliasing. The sensor unit includes provisions to collect auxiliary data such as sensor temperature and/or the state of two digital input and two digital output lines. The state of the discrete input lines is transmitted back to the controller unit. The discrete output signals represent the state of discrete input signals at the wireless controller unit.

The sensor unit includes a digital signal controller capable of the following actions:

- Generating a data sample rate clock
- Initiating data sampling
- Controlling the A/D converter and axis channel multiplexer
- Collecting axis channel data from the A/D converter
- Implementing an IIR filter algorithm to provide the required data output sample rate and frequency response
- Interfacing with the on-board wireless radio

Factors that influenced selection of the digital signal controller include:

- Chip physical size
- Supply voltage flexibility
- Power consumption at various signal data rates
- DSP functionality (must be sufficient to maintain data flow)
- Processor instruction cycle time (must be a low number of clock cycles, preferably 1)
- Useful on-board peripherals (UART, SPI, memory interface, etc.)

The unit also includes:

- On-board antenna tuned to the Bluetooth band
- I/O connector accessible through an environmentally sealed cover
 - Provides access to the discrete I/O signals
 - Provides access to a switch that is used to disconnect the battery
 - Saves battery when not in use
 - Provides access for battery recharging

Wireless Sensor Unit with External Transducer

A second type of wireless sensor node is under development as part of the ASMT initial Test Capability Project. This unit will be internally installed in a LAU-129 missile launcher, has an external triaxial sensor requiring excitation power from the unit, uses 28 VDC power, and uses an external antenna. All other building blocks used in the unit with the internal transducer are used in this unit. The intended transducer for use with this unit is the Kistler triaxial piezo-electric accelerometer K-Shear® #8792 M 04. See Figure 3.

Figure 3. Wireless Sensor unit with external transducer

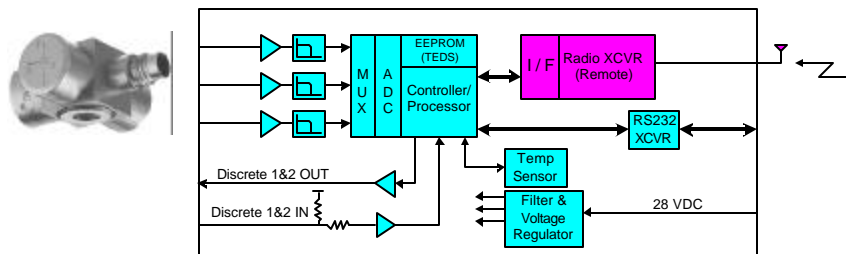

Wireless Controller Unit

The wireless controller unit is installed as part of a data system such as Teletronics MARM-2000 or MCDAU-2000. Its function is to receive wireless data from the sensors, and format the data in a fashion required by the host Data Acquisition Unit (“DAU”). The controller unit also sends control data and discrete channel data to the sensor units. The network controller implements command and control with the sensor units, uniquely addresses each sensor in its network, controls multiple sensors simultaneously, and provides access capability to the health status of each sensor unit in its network. In addition, the controller translates discrete inputs to the unit into discrete commands to the sensor units. On power up or as required, the controller programs the sensitivity and sample rate of the sensor channels. The frequency response of the sensor channels is automatically set to $\frac{1}{4}$ of the sample rate so, in effect, it is also programmed by the controller. Periodically the sensor will append additional data to the accelerometer data. This data includes the state of the discrete sensor inputs, temperature within the sensor module enclosure as well as other required “housekeeping” signals. As required, the controller can send commands to each sensor under its control, instructing it to change the logic state of its discrete output lines.



Airborne Wireless Sensor System Challenges

The challenges in the development of the wireless sensor system for airborne applications are numerous and required a systematic approach and careful study in many areas of discipline. These areas include:

- Transducer Selection
- Battery Selection and Power Conservation
- Frequency Study
- Wireless Radio and Antenna
- Network Throughput and Data Budget

MEMS Triaxial Transducers

Micro-Electro-Mechanical Systems (MEMS) is the integration of mechanical elements, sensors, actuators, and electronics on a common silicon substrate through microfabrication technology. While the electronics are fabricated using integrated circuit (IC) process sequences (e.g., CMOS, Bipolar, or BICMOS processes), the micromechanical components are fabricated using compatible "micromachining" processes that selectively etch away parts of the silicon wafer or add new structural layers to form the mechanical and electromechanical devices. MEMS brings together silicon-based microelectronics and micromachining technology, making possible a smaller, more highly integrated and lower power transducer than would have otherwise been possible.

Figure 4. 2-Axis MEMS Integrated Accelerometer

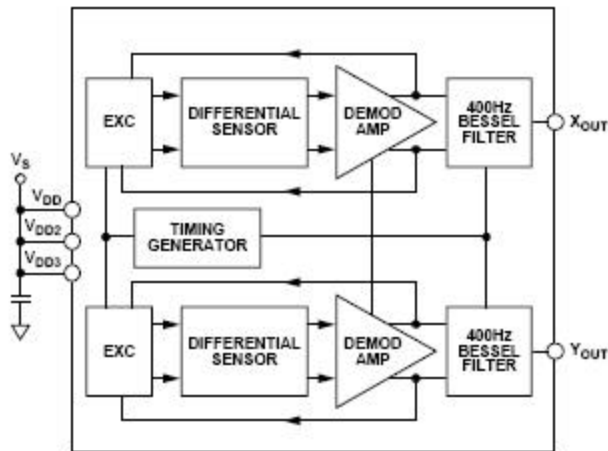

Figure 4 is a functional block diagram of a 2-axis MEMS integrated accelerometer. In addition to the accelerometers, excitation circuitry, differential amplifiers and low pass filters have been integrated into the package. The result is a small footprint, low profile package that consumes only a few milli-watts of power and requires a single low voltage power supply. The transducer outputs are single ended, high level, low impedance linear voltages.

The main drawback of MEMS based accelerometers is that with current technology, the acceleration range of currently available 3-axis MEMS accelerometers is limited to $\pm 10g$ or less. Higher acceleration ranges such as the $\pm 50g$ range of the system described in this paper require the use of a 2-axis unit and an additional single axis unit mounted exactly normal to the plane of the 2-axis unit.

Both the single and 2-axis devices are packaged in 5mm x 5mm ceramic leadless chip carriers (LCC) and are intended for surface mounting on printed circuit boards. The circuit board is firmly secured to the sensor housing at multiple points near the accelerometers to prevent vibrations that could originate on the circuit board. Additionally, the single axis unit is mounted on a secondary printed circuit board and in turn, firmly secured to the housing.

Battery Requirements

The power source of the wireless sensor is self-contained and capable of sufficient energy storage to provide at least four (4) hours of continuous operation. We estimate an energy storage capacity of 1.0 to 1.5 Watt-hours will be required. The battery must be lightweight and consume as little of the available sensor volume as possible. In addition, it must be able to supply short pulse currents of several 10s of milliamperes. The most severe requirement from the point of view of the battery is the required operating temperature range of -40°C to $+70^{\circ}\text{C}$.

A secondary (rechargeable) battery chemistry was originally considered and rejected because no practical candidates specified for operation at -40°C were found. Following discussions with the manufacturer and extensive temperature testing, a Lithium-Ion (Li-Ion) battery technology (the leading secondary battery chemistry) was chosen. This eliminates the requirement of gaining easy access to the battery while the sensor unit is installed on the aircraft by requiring only that the battery can be easily recharged while installed. The battery is lab replaceable.

The battery is low profile, which allowed installation just above the Printed Circuit Board. The battery is physically secured within the Radome. An on-board recharging circuit ensures that there is no direct access to the battery terminals, eliminating the possibility of shorting and causing damage to the battery and personnel during servicing. All that is required for recharging the battery is an external 5VDC power supply.

RF Frequency Study

Tests have been, and will continue to be, conducted in order to better understand the capabilities and challenges associated with the use of COTS wireless transceivers in aircraft data telemetry applications. Concerns involve both the potential of wireless devices to interfere with other aircraft electronic systems and conversely, the potential for aircraft electronics to corrupt wireless telemetry data. For example, aircraft S band transmitters operate from 2.2 – 2.45 GHz while Bluetooth devices operates between 2.4 – 2.483 GHz. Sharing of this frequency band may lead to serious loss of Bluetooth data due to receiver saturation whenever the aircraft S band transmitter is in operation. This

concern illustrates why wireless data telemetry testing within the vicinity of the aircraft is necessary to understand the limitations of the technology.

Line of sight is another issue in wireless technology. When implementing a low power wireless data link from one part of the aircraft to another, it is highly desirable to have an uninterrupted line of sight from transmitter to receiver. When this is not possible, the quality of the data link may suffer.

Field testing of prototypes using the selected Bluetooth transceiver and micro-controller have been completed and showed successful communication of up to 90 feet line of sight and also with various obstructions.

Conclusions

While design and implementation of a wireless system for aircraft telemetry applications poses a number of challenges, numerous benefits will result from such a system, provided it can be installed with minimal intrusiveness and without permanent modifications to the aircraft.

Before a robust wireless system for aircraft telemetry is realized, investigations must be carried out in a number of key areas. These areas include:

- Interference with/from other aircraft electronic systems
- Line of sight requirements between sensor and controller
- The effect of S band transmitters upon the wireless link
- Sensor power source related issues
- Characterizing data latency in the wireless link
- Data throughput
- Environmental qualification of hardware (to include electro-cleavable adhesive for externally installed wireless sensor modules)

This paper describes design concepts, considerations and concerns associated with the implementation of an ASMT type system. Subsequent papers will discuss specific issues and results encountered on the way to achieving the goal of developing a miniaturized, reliable, flexible and modular wireless data telemetry system that can be installed with minimal intrusiveness on a test article without the need for permanent modifications.

References

1. IEEE Standard 802.15.1, Wireless Medium Access Control and Physical Layer Specifications for Wireless Personal Area Networks, June 2002
2. IEEE 802.15.4, "Wireless Medium Access Control and Physical Layer Specifications for Low Rate Wireless Personal Area Networks," May 2003
3. IEEE 1451.2, "Standard for a Smart Transducer Interface for Sensors and Actuators - Transducer to Microprocessor Communication Protocols and Transducer Electronic Data Sheet (TEDS) Formats", September 1998
4. MEMS and Nanotechnology Clearinghouse website, <http://www.memsnet.org/>, June, 2006