

THE ARCHITECTURE OF AIRCRAFT INSTRUMENTATION NETWORKS

John Roach
VP Network Products Division
Teletronics Technology Corporation
Newtown, PA USA

ABSTRACT

The development of network-based data acquisition systems has resulted in a new architecture for supporting flight instrumentation that has the potential to revolutionize the way we test our aircraft. Unlike conventional flight test instrumentation, networks provide for a two-way communication path between all elements of the system, utilize packetized data, support communication protocols, have dynamic quality of service levels, can be subject to loss of data, utilize asynchronous transmission behavior and provide an even higher level of time synchronization. Different flight test architectures can be realized which combine each of the previous attributes in different ways; finding the best architecture for a set of given applications while minimizing cost and complexity is a very difficult problem. For the last 3 years, the Network Products Division at Teletronics has been involved in the design and evaluation of aircraft instrumentation networks for both customers and the iNET program. This paper describes the result of these efforts by discussing the high-level design of a modular architecture for an aircraft instrumentation network.

KEY WORDS

**NETWORK, DATA ACQUISITION, ARCHITECTURE, 1588, ETHERNET,
SWITCHING**

INTRODUCTION

Network-centric distributed data acquisition systems are common in many disciplines: transportation, remote sensing, war fighting, industrial manufacturing, research laboratories, and many other areas. Multiple vendors, standardization, market size, and existing widespread use of communication networks have contributed to their early adoption in these areas. One discipline that hasn't broadly benefited yet from this methodology is airborne instrumentation. In fact,

airborne data acquisition systems have changed very little over the last 20 years. Their technical growth has primarily been driven by advances in the area of digital filtering and the need for incorporation of newer avionic busses. Distributed data acquisition units operating as a system still employ time division multiplexing (TDMA) communication schemes. These schemes commonly utilize command and response busses like CAIS and serial streaming data like PCM. Although this approach is highly efficient, it has several drawbacks. These drawbacks have resulted in a rigid system architecture, system bandwidth limitations, the need for highly specialized recorders to acquire unique avionic busses that would otherwise overwhelm the system bandwidth, and unidirectional flow of data and control.

Even with these limitations, IRIG-106 Chapter 4 and its related standards have served as the baseline for testing virtually every major airborne system in use today. However, two underlying principles, upon which the success of these standards has been based, are rapidly changing. The complexity of the test article is rapidly increasing and serial unidirectional links are proving to be too restrictive for cost-effective testing. Additionally, RF spectrum, which at one time was plentiful, is quickly disappearing and the need for always-increasing dedicated bandwidth per test article is becoming too difficult to maintain. Fortunately, communication technology has given us a solution to these problems with its continuing development of higher speed communication links. The key to taking advantage of these links in our discipline is the adoption of packetized data streams that utilize shared bandwidth and support bi-directional communication. The key to the adoption of these technologies is a phased-in approach that maintains compatibility with existing assets and doesn't compromise the reliability and integrity of the data being collected.

BACKGROUND

The architecture of airborne distributed data acquisition systems has been rapidly moving towards a network-centric approach. While independent progress has been made in the past through individual efforts [1,2,3], the overall effort received a major boost in 2004 when the Director of the Central Test and Evaluation Investment Program (CTEIP) launched the integrated Network Enhanced Telemetry (iNET) effort [4]. The concept for this program grew out of discussions within the RCC Telemetry Group. The initial phase of the program, led by Sarnoff, focused on a "Needs Discernment Study" which identified 53 user test scenarios that documented primarily unmet needs in the aeronautical environment. These scenarios were then used as input into the next phase of the program, led by Boeing Phantom Works, which investigated a proposed architecture definition that could support the test scenarios. Over the last 18 months, iNET has adopted a systems engineering approach to reengineering telemetry focused on creating a telemetry network system (TmNS) architecture to enhance the capability of traditional point-to-point telemetry based on the derived need scenarios. The iNET effort has matured to the point where the physical characteristics of the proposed architecture are being developed. The program has recently completed its architecture development study and is entering a new phase to define which standards are needed in a range-wide telemetry network system (TmNS).

It will take some time before a standardized network-centric system architecture will be available to the flight test community. Aircraft manufacturers that have immediate needs to implement flight test systems to meet schedules can't afford to wait for standardization, and are pressing ahead with programs that require the use of different networking technologies as an element of the flight test

system backbone. It is primarily this need that led to Teletronics forming the Network Products Division (NPD) in 2005 to publicize our existing internal efforts to incorporate networking technology into our product lines so these immediate customer needs could be addressed. Initial work at Teletronics began in late 2002 when the company began acquiring engineering expertise in data communications as a result of beginning product development in support of the IEEE 1394 and Fibre Channel technologies used as part of the JSF Program. In late 2003, this development group began working with Boeing St. Louis in investigating ways of adapting Teletronics' existing McDAU technology to support the acquisition of Ethernet packets from an aircraft avionic bus. During 2004, Teletronics joined a multi-vendor team lead by Boeing Seattle to develop a network-centric data acquisition system from the ground up to support the flight test program for a new passenger aircraft. Our role in this effort was focused on the design and development of network-aware data acquisition units (DAUs) that would interface to the sensors and avionics buses used within the aircraft and output packetized data to the instrumentation network. During 2005 and 2006, Teletronics became more directly involved in supporting the research and technology needs of the iNET program. During the 2005 ITC Conference, Teletronics supported the iNET technology concept demonstration by providing software and hardware technology which allowed for the implementation of the Data Mining test scenario identified in the needs discernment [5,6]. At the 2006 ITC Conference, Teletronics supported the enhancement of the Data Mining technology demonstration by providing an Ethernet switch that supported IEEE 1588 and two network-capable DAUs that also supported IEEE 1588. Additionally, a PCM to Ethernet gateway was incorporated, allowing the integration of legacy DAUs to the network [7]. Also, during 2006, Teletronics supported the iNET program directly as a subcontractor to Boeing, providing network trade studies and implementation expertise specific to the test article segment of the TmNS.

The Network Products Division at Teletronics has as its charter the design and development of an IP-based networked instrumentation architecture for the data acquisition marketplace. We plan to accomplish this task by developing new hardware and software that allow our products to be programmed, controlled, transmit data and provide status using standard Internet Protocol. During our ongoing engineering process, we have been providing feedback regarding our experiences to the iNET development team in an effort to aid in the overall success of the iNET TmNS architecture. Additionally, we have been using the recommendations published by the iNET development team to guide our own engineering and product development process. Our objective is to realize an aircraft instrumentation implementation for networked data acquisition that is consistent with the proposed TmNS architecture. Our approach is tempered by the need to maintain backwards compatibility both with our own product lines as well as with the requirement that the quality of data that the flight test engineer obtains from a networked system is not compromised.

The objective of this paper is to describe the results of the engineering process used by the Network Products Division to develop its networked instrumentation architecture in a manner consistent with the goals of the company and fulfilling the requirements of the iNET proposed architecture. Additionally, we will identify when decisions have been made where logical or functional elements of the TmNS are being assigned to a physical implementation. More importantly, we show how our instrumentation architecture allows for its evolution from a primarily legacy-driven implementation to a packet-driven implementation. Software management of this architecture is described in a companion paper [8].

TmNS ARCHITECTURE OVERVIEW

The overall iNET architecture is quite broad and can be logically partitioned into six systems: Telemetry Network System, Peripherals, Network Management, Spectrum Assignment Management, Peripheral Configuration Applications, and Peripheral Management Applications. The relationship between these systems and the domain physical architecture is as follows:

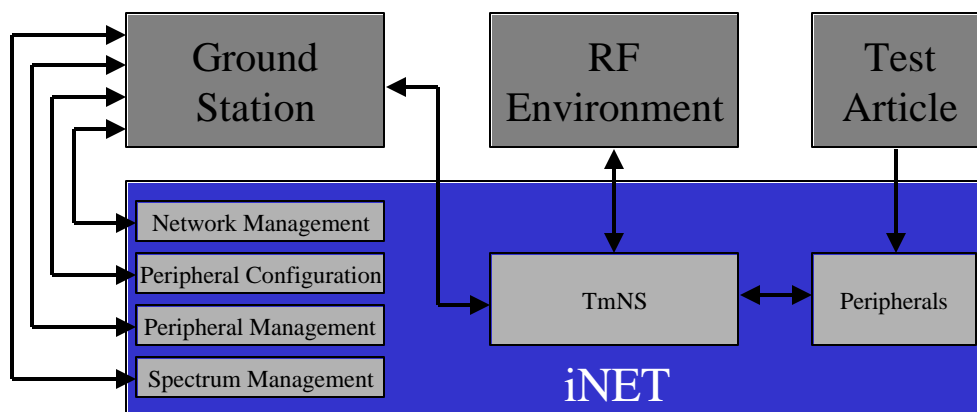

The management and configuration systems are primarily realized by software, while the TmNS and peripherals reflect an implementation dependent mixture of software and hardware. The focus in this paper is on the Test Article Segment (TAS) of the TmNS and the peripherals. The management and configuration systems of the iNET architecture and how they have been realized within the Teletronics implementation are covered in a companion paper. The TmNS system can be further decomposed into the following segments:

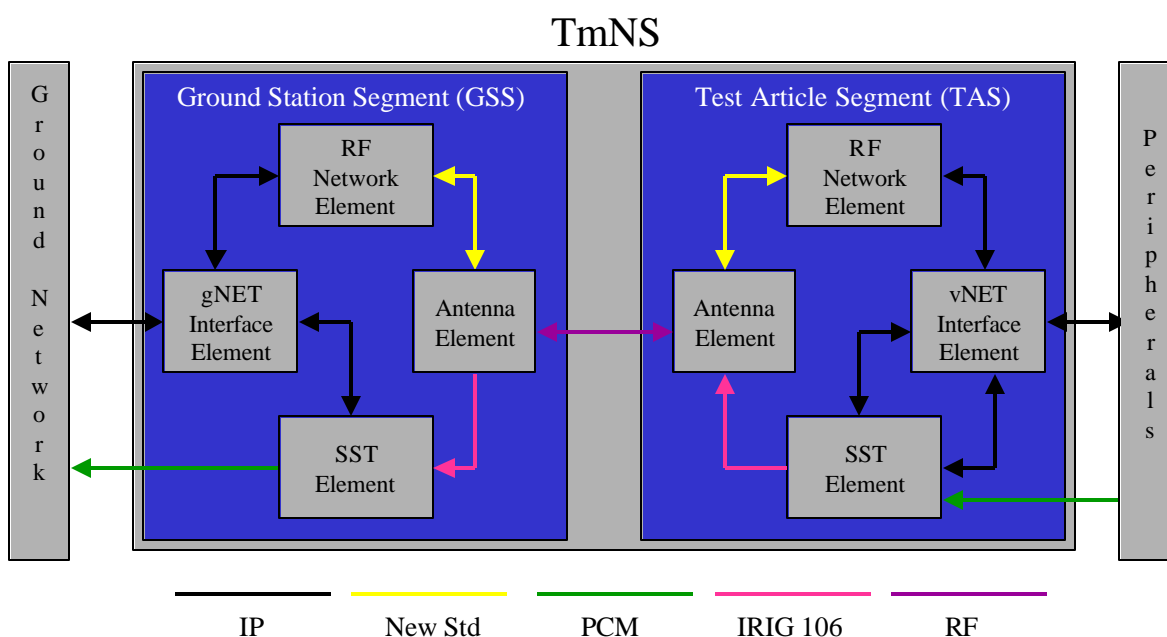

The TmNS can be partitioned into the two endpoints of a communication link. The Ground Station Segment (GSS) corresponds to that portion of the ground network where serial streaming telemetry (SST) is received from Test Articles (conventional telemetry) and where packetized IP data is exchanged (sent and received) to/from Test Articles. The Test Article Segment (TAS) corresponds to that portion of the test article instrumentation network where SST is sent to the GSS and where packetized IP data is exchanged (sent and received) to/from the ground network.

The TAS RF Network Element provides the bridge between the IP portion of the test article network and the RF portion of the TmNS. The TAS SST Element provides the bridge between the PCM and CAIS portion of the test article instrumentation system and the RF portion of the TmNS. The TAS SST Element preserves the legacy serial streaming telemetry used in flight test while the TAS RF Network Element implements the new bi-directional packetized communication link of the TmNS. Both elements logically share the use the TmNS TAS Antenna Element, though, physically, they will have independent structures as both functions occur simultaneously. The TAS vNET Interface Element functions as the gateway for IP packets between the test article network and the TmNS. In a similar manner, the TmNS assumes the SST Element functions as a gateway (even though in one direction only) between the TmNS and the PCM/CAIS portion of the test article instrumentation system. The actual function and physical relationship between the PCM/CAIS (legacy) and IP segments of the instrumentation system aren't defined by proposed TmNS architecture. Clearly, this is an implementation issue controlled by the vendors and the customer's existing assets. However, iNET's stated goal in accomplishing the predefined test scenarios requires cooperation and communication between the legacy and IP segments of the instrumentation system. In the diagram above, there are two IP connections shown between the SST element and the vNET Interface Element. In the TmNS architecture, one link is assumed to be unclassified and used only to control the SST transmitter, while the other link is assumed to be classified and is used to present IP packets to the SST controller for possible incorporation into the serial telemetry stream. Additional comments about this arrangement are found in the next section.

AN INSTRUMENTATION NETWORK

The following diagram illustrates the lowest functional level specified by the proposed iNET TmNS TAS architecture:

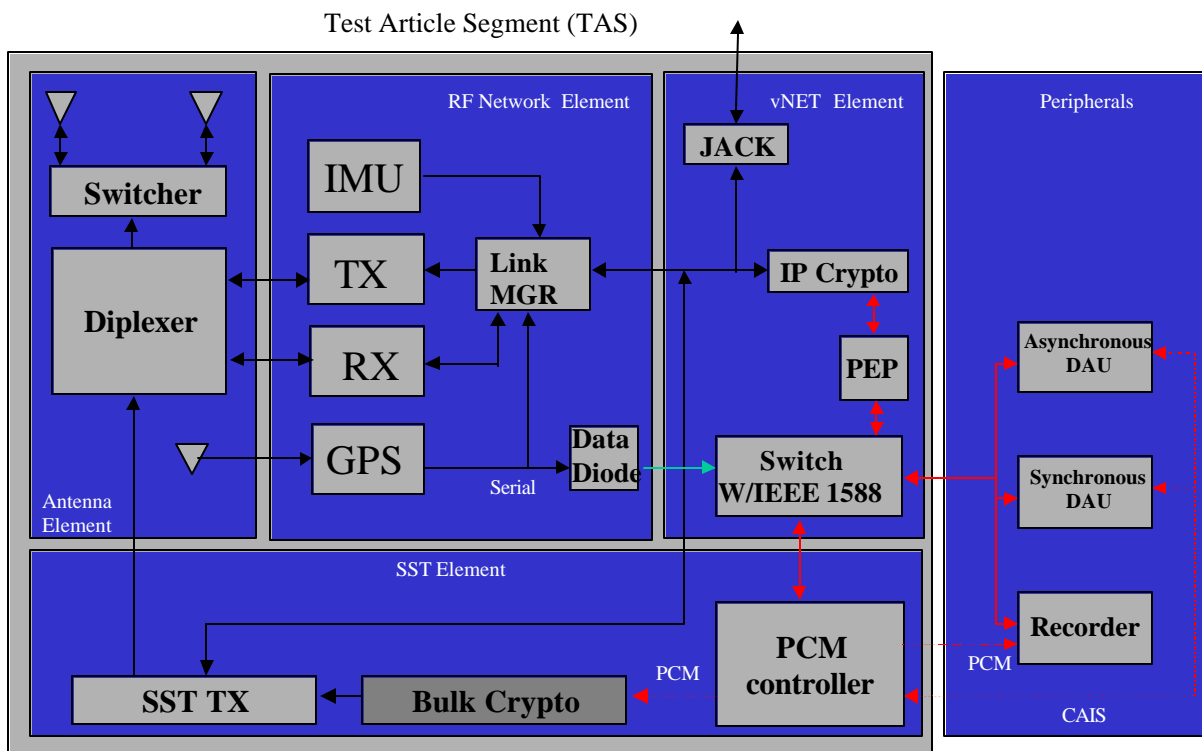

Each of the four elements within the TmNS TAS is shown in more detail along with the communication links needed for interfacing with three typical peripherals. A functional description of each of the components in the diagram and their relationships to each of the four elements follows:

Antenna Element

- **Switcher** – Used to select which antenna on the test article is being used for the transmission and reception of data to/from the GSS. The physical orientation of the test article with respect to line of sight of the ground antennas dictates this need.
- **Diplexer** – Used to isolate the different frequencies being used for the network and the SST transmissions being fed to the antenna.

RF Network Element

- **IMU** – An Inertial Measurement Unit is used to detect changes in position and orientation of the test article. It is used in conjunction with a GPS to produce information useful to determine which antenna(s) have line of sight with a ground antenna.
- **TX** – The IP packet RF transmission component.
- **RX** – The IP packet RF reception component.

- **GPS** – A global positioning system used to generate both positional information of the test article and provide the timing reference for clock synchronization within the Link Manager and the instrumentation network.
- **Link Manager** – This component provides for the link layer management of the TDMA-based OFDM transceiver defined by the TmNS architecture. It accepts IP packets destined for an address on the ground and schedules them for transmission based on its assigned timeslots in the TmNS. It also accepts IP packets from the ground destined for an address within the test article and places them on the internal network.
- **Data Diode** – A one-way communication device to separate red/black systems. Its used to allow for the transport of NEMA (National Electrical Manufacturers Association) data between the GPS and the Switch. The output of a standard GPS consists of text messages in NEMA standard format that contain position and time information.

vNET Element

- **Jack** – An external IP connection used to connect in the hanger to the ground service equipment.
- **IP Encryption** – This device encrypts or decrypts IP packets as they pass between the Link Manager and the Switch. Its purpose is to maintain separation between the classified and unclassified portions of the test article.
- **Performance Enhancing Proxy (PEP)** – A network agent designed to improve the end-to-end performance of communication protocols such as TCP. They are primarily used to overcome the issue of TCP window sizes being set too small on high-latency links.
- **Switch** – An ethernet switch is used to provide data link-layer routing of IP packets in the test article. In addition, this switch is designed to provide hardware and software support of IEEE 1588, a high-accuracy clock synchronization protocol. The switch provides the IP traffic switching of packets between the TmNS and the peripherals in the test article.

SST Element

- **PCM Controller** – This device acts as a CAIS Bus master to collect sampled parameters from peripherals and generate two PCM output streams, one output stream for input to the test article recorder and a second output stream for input to the serial streaming transmitter.
- **Bulk Encryption** – The device that performs bit-level encryption of the serial streaming telemetry data.
- **SST TX** – The serial streaming telemetry transmitter of the test article. Its purpose is to maintain compatibility with the existing low-latency data transmission subsystem in today's flight test instrumentation system.

The previous diagram and highlighted components document the proposed TmNS Test Article Segment architecture as it currently exists. Over the last year, the Network Products Division at Teletronics has been actively working to integrate its own work in the development of aircraft instrumentation networks into an architecture compatible with the proposed TmNS system specification being developed by iNET. Our efforts have yielded an architecture that closely matches the TmNS proposed architecture, however, when evaluated at an implementation level, there are significant structural differences that reflect our own product line decisions, development experiences, and customer requirements. These differences are detailed below.

1. The RF Network Element makes use of a single GPS to provide synchronization signals and positional information to the Link Manager and timing information in the form of NEMA messages to the Switch in the vNET Interface Element. The timing information is used to convey clock synchronization with the Switch for 1588-based time propagation within the test article instrumentation network. The use of ASCII-based character strings over a very low speed serial connection to convey accurate timing information to the switch is not sufficient from our viewpoint to achieve the sub-microsecond accuracy needed by the peripherals. In our implementation, we have chosen to locate one GPS directly in the Link Manager, and a second GPS directly within the 1588 core switch.
2. The SST Element shows an IP connection between the SST transmitter and the unclassified portion of the test article IP network. TTC does not find it practical to require modification of all SST transmitters to support IP; almost all transmitters current make use of a RS-232/422 serial port for configuration purposes. Our implementation has chosen to make use of a serial port on the Link Manager to allow for two-way communication between the SST transmitter and TmNS. Since the Link Manager will be a newly developed component, we have chosen to assign the SST management functions to this device also.
3. The TmNS TAS defines synchronous and asynchronous DAUs as supporting both an IP interface and a command/reply bus as needed. The IP interface would be primarily used as a configuration and status interface and the command/reply bus would be used to control low-latency measurements. Forcing all customers to potentially replace all existing legacy CAIS assets to support the IP configuration interface would be too great of a burden. We have chosen to make use of PCM-to-network gateways to allow for existing CAIS-only assets to be integrated into the test article network unmodified.
4. The TmNS TAS shows the recorder supporting two recording interfaces, IP and PCM. The PCM interface is used for parameters obtained from the command/reply bus and the IP interface would be used for any peripherals attached directly to the instrumentation network. From an architecture point of view, TTC believes maintaining two classes of data (from the recorder's point of view) will make the implementation of the test scenarios cumbersome and inefficient. Making use of PCM-to-network gateways allows us to build recorders designed for efficient IP packet recording.

5. The PCM controller is logically placed as a function of the TmNS TAS SST Element. Its role is to act as the master on the command/reply bus, to gather sampled parameters from the DAUs, and generate PCM output for use by the SST Element and by the recorder. In actual instrumentation systems, the PCM or CAIS controller commonly has multiple roles in the data acquisition system and can often support I/O cards that sample data from avionics buses or other sensors. Its inclusion into the TAS SST element is confusing from our viewpoint and we have chosen to reassign its role in the architecture as a peripheral device. Additionally, the need for an IP connection to the PCM controller may limit the use of legacy equipment; our strategy of using PCM-to-network gateways eases the reuse of existing PCM or CAIS equipment.
6. In order to further the reuse of legacy DAUs, TTC has chosen to preserve the command/replay bus (CAIS) as the configuration mechanism for these units. The PCM-to-Network gateway assumes responsibility for providing the IP interface used to configure the CAIS Bus master, while collecting data and status from its PCM output for transmission on the test article network. In addition, TTC has chosen to provide IRIG timing output on the Switch acting as the 1588 grandmaster. This allows us to synchronize the timestamps on both the legacy DAUs and the network DAUs to the same time source.

Updating the previous TmNS TAS functional diagram to reflect our implementation choices is reflected below:

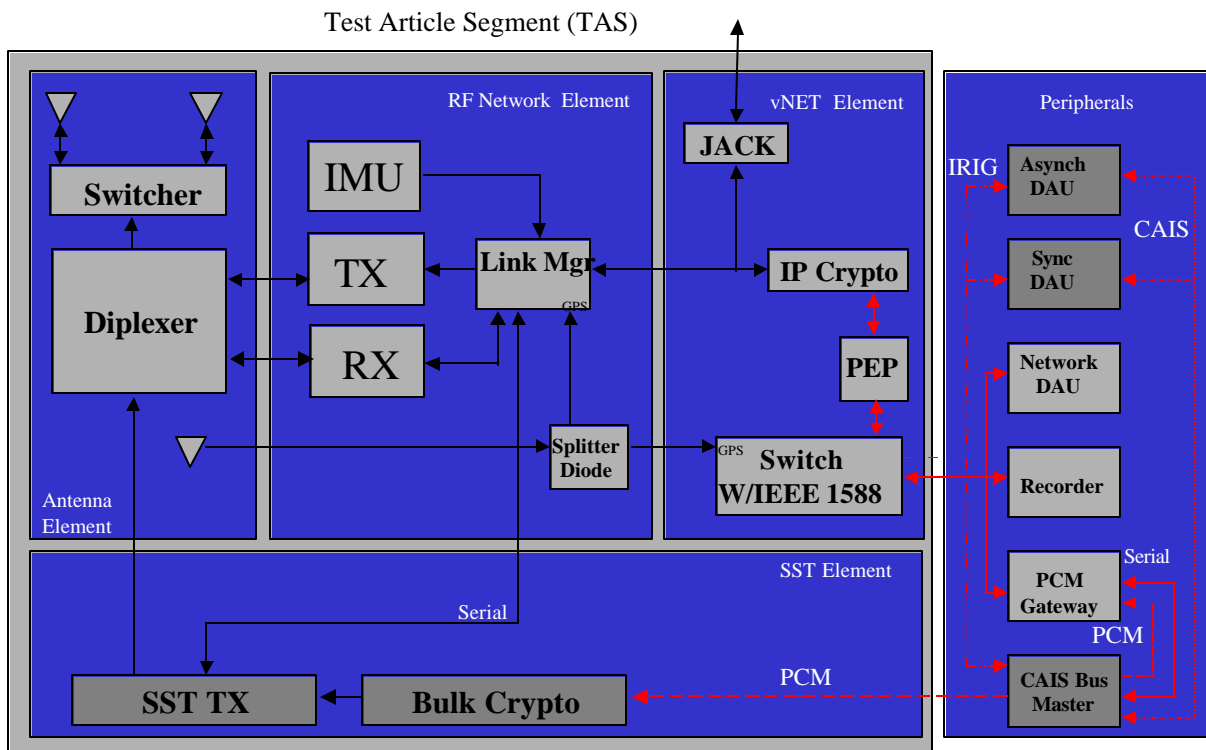

The components in dark grey reflect legacy hardware that can be reused in our modified TmNS architecture. Initially, there could be no network capable DAUs in the test article instrumentation network itself. All of the acquired data would enter the network through one or more PCM-to-Network gateways. Evidentially, all legacy DAUs may transition to DAUs that support IP interfaces. At that point, the PCM-to-Network gateway is replaced with a Network-to-PCM gateway to generate the PCM needed by the legacy serial streaming telemetry. This transition could only occur once the instrumentation network is capable of providing upper bounds on packet latency for packets that contain parameters needed for SST.

SUMMARY

This paper has focused on examining the proposed TmNS architecture as put forth by the iNET program. During this examination, we have described modifications of this architecture that reflect our experience in developing instrumentation networks for aircrafts. Our goals are to balance the need to maintain compatibility with legacy assets, maximize flexibility, while preserving the functionality inherent in the proposed TmNS architecture to implement the test scenarios developed during the “Needs Assessment”.

REFERENCES

1. Berdugo, Albert A.; “Design of a Gigabit Data Acquisition and Multiplexer System”, Proceedings of the International Telemetry Conference (ITC 2003)
2. Sweeney, Paul; “Why Change from PCM”, Proceedings of the International Telemetry Conference (ITC 2005)
3. O’Connell, Tim; “Packet-Based Telemetry Networks Over Legacy Systems”, Proceedings of the International Telemetry Conference (ITC 2005)
4. Skelley, Daniel; “iNET Project – Special Session”, Proceedings of the International Telemetry Conference (ITC 2005)
5. Dawson, Dan; “The Integration of Ground-based Real-time Telemetry Processing, On-board Chapter 10 Aircraft Data Recorders, and 802.11G Links,” Proceedings of the International Telemetry Conference (ITC 2005)
6. Grace, Thomas; Roach, John; “Vehicle Network Concept Demonstration”, Proceedings of the International Telemetry Conference (ITC 2005)
7. Grace, Thomas; Roach, John; “1588-Enhanced Vehicle Network Concept Demonstration”, Proceedings of the International Telemetry Conference (ITC 2006)
8. Roach, John; “Design of a Configuration and Management Tool For Instrumentation Networks”, Proceedings of the International Telemetry Conference (ITC 2007)