

Wireless Sensor System for Airborne Applications

Albert Berdugo, Hy Grossman, and Nicole Schofield

Teletronics Technology Corporation

Steven Musteric
46th Test Systems Squadron
Eglin Air Force Base, FL

Abstract

Adding an instrumentation / telemetry system to a test vehicle has historically required an intrusive installation for wiring and powering all elements of the system from the sensor to the telemetry transmitter. In some applications there is need for a flexible and modular instrumentation and telemetry system that can be installed with minimal intrusiveness on an aircraft without the need for permanent modifications. Such an application may benefit from the use of a miniaturized, inexpensive network of wireless sensors. This network will communicate its data to a central unit installed within the aircraft.

This paper describes recent efforts associated with the Advanced Subminiature Telemetry System (ASMT) Initial Test Capability Project. It discusses the challenges in developing a wireless sensor network system for use in an airborne environment. These include selection of frequencies, COTS wireless devices, batteries, system synchronization, data bandwidth calculations, and mechanical structure for external installation. The paper will also describe the wireless network architecture as well as the architecture of the wireless sensor and the central control unit.

Key Words

Network, Miniaturized, Non-Intrusive, Wireless sensor, Bluetooth, Zigbee, IEEE 802.15.4, Data Acquisition

Introduction

Flight test vehicles require a certain degree of wiring and installation modification to accommodate flight test equipment. In most cases this equipment is used either in a test vehicle dedicated for flight test, or in production vehicle to solve a problem or test a new system. When a dedicated test vehicle is used, it is expected that the installation of test equipment will require a high degree of intrusiveness. The use of an instrumentation system in a production vehicle imposes on the instrumentation engineer to minimize wiring and modification. A small inexpensive network based instrumentation/telemetry system that can be non-intrusively installed in a variety of configurations and locations

on a test vehicle without significantly impacting the performance of the system being tested has been the goal of the ASMT project and instrumentation engineers. The implementation of a complete non-intrusive flight test system is both difficult and beyond the scope of this paper. The possible use of a sub-system acquiring data from several wireless sensors with minimal intrusiveness is both worth investigating and achievable. This paper will discuss the challenges and barriers that require in depth study and test in order to implement and use such a system on a test vehicle. The design of a wireless sensor to be installed on the skin of a test vehicle poses challenges that are far beyond a simple data acquisition design. We will evaluate the challenge, the decision making process, and the possible direction to be taken for realizing a successful wireless sensor design for airborne flight test applications.

System Overview

The system is comprised of a group of wireless sensors for data acquisition that communicate with an on-board data system. The system includes wireless sensor units with separate installation, and a wireless control unit residing within the data system that collects data from the network of wireless sensors. See Figure 1 for the system diagram.

Figure 1. Wireless sensor system diagram

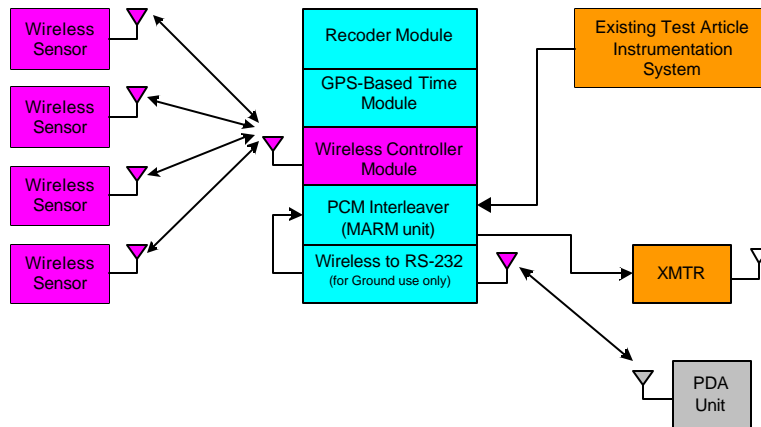

The wireless sensor incorporates transducers, signal conditioning, an acquisition controller, a processor, power (battery), a wireless radio, and an antenna into a sealed, aerodynamically shaped, miniaturized package. It is intended for external installation on a test vehicle via the use of an electro-cleavable adhesive. For some applications, this wireless sensor unit may require an external transducer and an external antenna installation. In this application, the only elements installed on the skin of the test vehicle are the transducer and the antenna. Other applications may require the use of available power near the sensor unit location, which eliminates the need of a battery. This is very useful in cases when external transducers require excitation power.

The wireless control unit is part of the on-board data system for controlling and collecting data from the wireless sensors. The control unit provides a self-discovery mechanism for identifying the sensors in its network, facilitating the sensor calibration process,

programming acquisition variables in the sensor units, and providing two way communication with all the sensors in its network. The installation of the controlling unit as part of the data system may require an external remote antenna for communication with the wireless sensors.

As an added complexity, the system allows for multiple wireless control units within an on-board data system. Each control unit communicates with its network of wireless sensors for control and data.

The paper will describe in detail three types modules currently being developed under the ASMT Initial Test Capability Project. It also describes some of the specific development studies being conducted to support development of the system. The three types of units being developed are:

- Wireless sensor unit with integrated transducer and battery
- Wireless sensor unit with external transducer and uses external 28 VDC power
- Wireless control unit

Wireless Sensor Unit with Integrated Transducer and Battery

This wireless sensor node is a stand-alone assembly installed externally on the skin of the test article. It conditions one (1) triaxial accelerometer, digitizes and encodes the data for wireless transmission to a collector node. The sensor node is processor based and allows user programmable control of sensor variables and data filtering. The sensor programmable variables include channel sample rate, gain, offset, and anti-alias filter cutoff frequency characteristics. All calibration and signal conditioning will be preset within the unit. The sensor node is fully programmable via the wireless connection from the controller node. The unit operates from a single replaceable internal battery for a duration of up to four hours. It includes an on-board non-volatile memory for storage of critical information such as module identifier, channel setup, transducer calibration data, etc. An IEEE-1451.0 “like” Transducer Electronic Data Sheet (TEDS) datasheet is employed. See Figure 2.

Figure 2. Wireless Sensor unit with built-in transducer

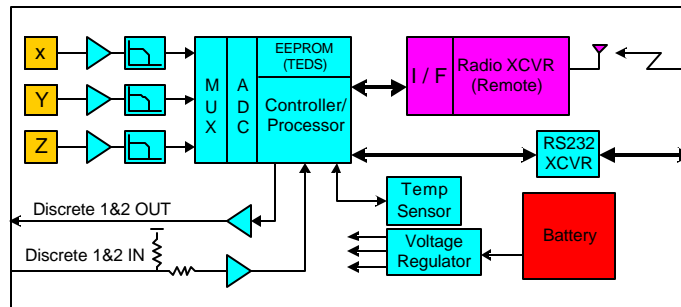

The internal triaxial accelerometer is optimized for measuring low frequency vibration response. The sensor allows a programmable sample rate of up to 200 samples/sec, and has a programmable filter whose -3dB frequency is automatically set to 1/4 of the sample

rate (1 Hz to 50 Hz). The channel filter has a 40-tap FIR characteristic. The sensor unit includes a fourth channel to provide auxiliary data such as sensor temperature and/or the state of several digital I/O lines at programmable update rate. The discrete output signals represent the state of discrete input signals at the wireless controller unit.

The sensor unit includes a digital signal controller capable of the following actions:

- Generating a data sample rate clock
- Initiating data sampling
- Controlling the A/D converter and axis channel multiplexer
- Collecting axis channel data from the A/D converter
- Implementing a FIR filter algorithm with decimation to provide the required data output sample rate and frequency response
- Interfacing with the on-board wireless radio

Factors that influence selection of the digital signal controller include:

- Chip physical size
- Supply voltage flexibility
- Power consumption at various signal data rates
- DSP functionality (must be sufficient to maintain data flow)
- Processor instruction cycle time (must be low number of clock cycles, preferably 1)
- Useful on-board peripherals (UART, SPI, memory interface, etc.)

Wireless Sensor Unit with External Transducer

A second type of wireless sensor node is under development as part of the ASMT initial Test Capability Project. This unit will be installed internally in a LAU-129 missile launcher, has an external triaxial sensor requiring excitation power from the unit, uses 28 VDC power, and uses an external antenna. All other building blocks used in the unit with the internal transducer are used in this unit. The intended transducer for use with this unit is the Kistler triaxial piezo-electric accelerometer K-Shear® #8792 M 04. See Figure 3.

Figure 3. Wireless Sensor unit with external transducer

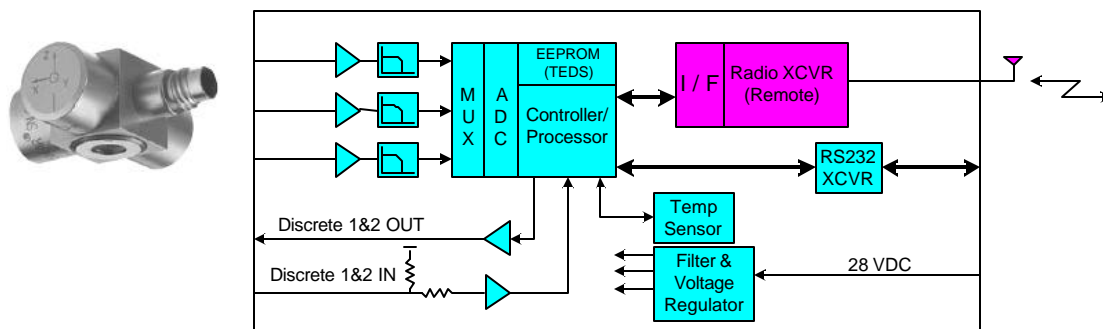

Wireless Controller Unit

The wireless controller unit is installed as part of a data system such as Teletronics MARM-2000 or the MCDAU-2000. Its function is to receive wireless data from the sensors, and format the data in a fashion required by the host Data Acquisition Unit (“DAU”). The controller unit also sends control data and discrete channel data to the sensor units. The network controller implements command and control with the sensor units, uniquely addresses each sensor in its network, controls multiple sensors simultaneously, and provides access capability to the health status of each sensor unit in its network. In addition, the controller translates discrete inputs to the unit into discrete commands to the sensor units. On power up or as required, the controller programs the sensitivity and sample rate of the sensor channels. The frequency response of the sensor channels is automatically set to $\frac{1}{4}$ of the sample rate so in effect, it is also programmed by the controller. Periodically the sensor will append additional data to the accelerometer data. This data includes the state of the discrete sensor inputs, temperature within the sensor module enclosure as well as other required “housekeeping” signals. As required, the controller can send commands to each sensor under its control, instructing it to change the logic state of its discrete output lines.

Airborne Wireless Sensor System Challenges

The challenges in the development of the wireless sensor system for airborne applications are numerous and require a systematic approach and careful study in many areas of discipline. These areas include:

- Transducer Selection
- Battery Selection and Power Conservation
- Frequency Study
- Wireless Radio and Antenna
- Network Throughput and Data Budget

MEMS Triaxial Transducers

Micro-Electro-Mechanical Systems (MEMS) is the integration of mechanical elements, sensors, actuators, and electronics on a common silicon substrate through microfabrication technology. While the electronics are fabricated using integrated circuit (IC) process sequences (e.g., CMOS, Bipolar, or BICMOS processes), the micromechanical components are fabricated using compatible “micromachining” processes that selectively etch away parts of the silicon wafer or add new structural layers to form the mechanical and electromechanical devices. MEMS brings together silicon-based microelectronics and micromachining technology, making possible a smaller, more highly integrated and lower power transducer than would have otherwise been possible.

Figure 4. 2-Axis MEMS Integrated Accelerometer

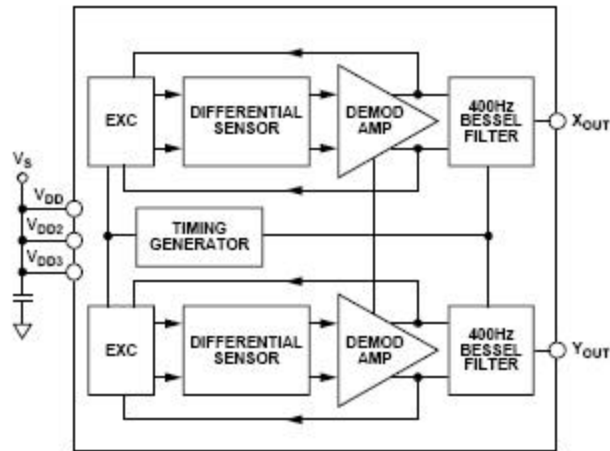

Figure 4 is a functional block diagram of a 2-axis MEMS integrated accelerometer. In addition to the accelerometers, excitation circuitry, differential amplifiers and low pass filters have been integrated into the package. The result is a small foot-print, low profile package that consumes only a few milliwatts of power and requires a single low voltage power supply. The transducer outputs are single ended, high level, low impedance linear voltages.

The main drawback of MEMS based accelerometers is that with current technology, the acceleration range of currently available 3-axis MEMS accelerometers is limited to $\pm 10g$ or less. Higher acceleration ranges such as the $\pm 50g$ range of the system described in this paper require the use of a 2-axis unit and an additional single axis unit mounted exactly normal to the plane of the 2-axis unit.

Both the single and 2-axis devices are packaged in 5mm x 5mm ceramic leadless chip carriers (LCC) and are intended for surface mounting on printed circuit boards. The circuit board must be firmly secured to the sensor housing at multiple points near the accelerometers to prevent vibrations that could originate on the circuit board. Additionally, the single axis unit must be mounted on a secondary printed circuit board and in turn, firmly secured either to the housing or to the main printed circuit board. However it is mounted, the single axis device must be oriented exactly normal to the 2-axis device.

Battery Requirements

The power source of the wireless sensor must be self-contained and capable of sufficient energy storage to provide at least four (4) hours of continuous operation. We estimate an energy storage capacity of 1.0 to 1.5 Watt-hours will be required. The battery must be lightweight and consume as little of the available sensor volume as possible. In addition, it must be able to supply short pulse currents of several 10s of milliamperes. The most severe requirement from the point of view of the battery is the required operating temperature range of -40°C to $+70^{\circ}\text{C}$.

Candidate battery chemistries are Lithium Manganese Dioxide (LiMnO_2) and Lithium Thionyl Chloride (LiSOCl_2). Lithium batteries are lightweight and have very high energy densities for their size. Because any Lithium cell used to power the wireless sensor will be small, the amount of Lithium present will be insufficient to pose any explosion or fire risk, should the battery housing become damaged. Both candidate battery chemistries are primary (non-rechargeable). Secondary (rechargeable) battery chemistries were considered and rejected because no practical candidates specified for operation at -40°C were found. Recent advances in Lithium-Ion (Li-Ion) battery technology (the leading secondary battery chemistry) suggest this situation may improve so we continue to monitor new developments and product offerings in this area.

Of batteries that are commercially available now, a LiSOCl_2 cell equivalent in volume to a $\frac{1}{2}$ AAA size cell (10mm dia. x 25mm long), would be able to satisfy the above stated power and environmental requirements.

Additional physical requirements exist for the wireless sensor power source:

- Provision must be made for easy replacement (primary cell) or easy recharging (secondary cell).
- The battery must be securely mounted to the sensor housing to prevent vibration yet still allow for convenient battery replacement.
- Electrical connections to battery must be positive and insensitive to vibration yet they must still facilitate battery replacement.

RF Frequency Study

Tests will be conducted in order to better understand the capabilities and challenges associated with the use of COTS wireless transceivers in aircraft data telemetry applications. Concerns involve both the potential of wireless devices to interfere with other aircraft electronic systems and conversely, the potential for aircraft electronics to corrupt wireless telemetry data. For example, aircraft S band transmitters operate from 2.2 – 2.45 GHz while Bluetooth devices operates between 2.4 – 2.483 GHz. Sharing of this frequency band may lead to serious loss of Bluetooth data due to receiver saturation whenever the aircraft S band transmitter is in operation. This concern illustrates why wireless data telemetry testing within the vicinity of the aircraft is necessary to understand the limitations of the technology.

Line of sight is another issue in wireless technology. When implementing a low power wireless data link from one part of the aircraft to another, it is highly desirable to have an uninterrupted line of sight from transmitter to receiver. When this is not possible, the quality of the data link may suffer. For this and other reasons as well, other wireless COTS technologies, such as Zigbee, that may not require an uninterrupted line of sight, are being studied as possible alternatives to Bluetooth for providing accurate data transmission without the benefit of a line of sight radio link.

Wireless Radio and Antenna

Bluetooth (IEEE-802.15.1) and Zigbee (IEEE-802.15.4) are both potential candidate technologies for wireless data telemetry applications. Each has attributes that would

make it the preferred choice in a given application. Both Bluetooth and Zigbee operate in approximately the same frequency range. Bluetooth ranges from 2.4 – 2.483 GHz with 79, 1 MHz wide RF channels (generally, 2.408 – 2.480 GHz is the operating range) transmitting up to 2.1Mbps (Bluetooth 2.0). Zigbee based systems are configured to operate at 2.4 GHz (with data rates up to 250 kbps), or alternatively at 915 MHz (with data rates up to 40 kbps), or 868 MHz (with data rates up to 20 kbps).

In terms of power consumption and device size, Zigbee and the latest version of Bluetooth (2.0) are comparable. The power requirement of Bluetooth 2.0 devices is half that of previous versions.

Zigbee devices are specified to operate over distances of up to 100 meters as are Bluetooth class 1 devices. Bluetooth class 2 devices are specified for distances up to 10 meters. Both wireless communication systems have their own security protocols. Zigbee security is defined by a 128 AES plus application layer security; Bluetooth security uses 64 and 128 bit encryption. The different security systems must be evaluated through testing in the aircraft environment. One advantage of Zigbee devices is their connection time. Zigbee can join existing networks in less than 30ms, whereas, Bluetooth 2.0 devices require approximately 3-5 seconds.

Zigbee has the unique ability to receive information from a device outside the network, even if this receiver is not the principal controller, and then forward the information (without reading the data it is transmitting). The device simply looks at the destination and sends the data on to the controller. This capability may be useful in situations where a direct line of sight between an outlying sensor and controller is not possible.

One version of the wireless sensor described in this paper employs an internal microstrip antenna as part of the main PC board. This antenna is omni-directional and lies wholly within the sensor enclosure, greatly simplifying sensor mounting. On the other hand, signal strength of the RF link becomes a consideration in sensor placement along with the optimal position for measuring vibrations.

A second version of the wireless sensor is mounted within the aircraft fuselage and employs an externally mounted antenna. This arrangement clearly requires a more intrusive installation but may provide greater flexibility in sensor placement. External antennas are connected to the sensor via a coaxial cable link that should be kept as short as possible to minimize RF signal attenuation. The choice of coaxial cable material is based on a trade-off between thinner cables that can be more easily routed along the exterior of an aircraft and heavier cables that will introduce less RF attenuation per foot of travel. Finally, an external antenna need not be omni-directional. A properly oriented directional antenna can significantly improve the robustness of the RF data link.

Conclusions

While design and implementation of a wireless system for aircraft telemetry applications poses a number of challenges, numerous benefits will result from such a system, provided it can be installed with minimal intrusiveness and without permanent modifications to the aircraft.

Before a robust wireless system for aircraft telemetry is realized, investigations must be carried out in a number of key areas. These areas include:

- Interference with/from other aircraft electronic systems
- Line of sight requirements between sensor and controller
- The effect of S band transmitters upon the wireless link
- Sensor power source related issues
- Characterizing data latency in the wireless link
- Data throughput
- Environmental qualification of hardware (to include electro-cleavable adhesive for externally installed wireless sensor modules)

This paper describes initial design concepts, considerations and concerns associated with the implementation of an ASMT type system. Subsequent papers will discuss specific issues and results encountered on the way to achieving the goal of developing a miniaturized, reliable, flexible and modular wireless data telemetry system that can be installed with minimal intrusiveness on a test article without the need for permanent modifications.

References

1. IEEE Standard 802.15.1, Wireless Medium Access Control and Physical Layer Specifications for Wireless Personal Area Networks, June 2002
2. IEEE 802.15.4, "Wireless Medium Access Control and Physical Layer Specifications for Low Rate Wireless Personal Area Networks," May 2003
3. IEEE 1451.2, "Standard for a Smart Transducer Interface for Sensors and Actuators - Transducer to Microprocessor Communication Protocols and Transducer Electronic Data Sheet (TEDS) Formats", September 1998
4. MEMS and Nanotechnology Clearinghouse website, <http://www.memsnet.org/>, June, 2006