

CONNECTING NETWORK-BASED DATA ACQUISITION NODES TO THE NETWORK

John Hildin
Director of Network Systems
Teletronics Technology Corporation
Newtown, PA USA

ABSTRACT

Unlike communications protocols that are bus-based or multi-drop (e.g., CAIS Bus, Fibre Channel, RS-485), Ethernet relies on a point-to-point connection topology. One reason for this approach is to allow network nodes to negotiate their individual mode of communication with the network, i.e., link speed and duplexity.

The goals of this paper are twofold. The first goal is to describe the process of link negotiation between nodes. This will include some of the details of how two physical layer devices establish communication. The second goal is to show how networked data acquisition nodes are physically connected within the overall system.

KEY WORDS

Network, Data Acquisition, Physical Layer, Ethernet

INTRODUCTION

There are various communication bus technologies that have been used in test articles. In many cases these buses utilize different physical connections or topologies. With the use of Ethernet within the test article, the instrumentation engineer must be aware of how to interconnect test devices or nodes on the bus. Understanding how Ethernet-based equipment connects, at the physical layer, will ease the process of designing and implementing a network-based system.

COMMONLY USED BUSES

Although there are many communications buses used on a myriad of vehicles, several well-known buses are presented here for illustration.

The CAIS Bus or Common Airborne Instrumentation System Bus is a command/reply type bus that uses separate physical cabling for the transmission of command messages and reply messages. Commands are transmitted from the controlling device to one or more remote devices. Each remote has its own address on the bus. The topology of the CAIS Bus is best described as a multi-point type bus. Each device “taps” off the bus, connecting to it electrically. An electrical termination is placed at the end of the bus to reduce signal reflections. The physical bus forms a transmission line made up of the controller, remotes, cabling, connectors and the bus termination. Figure 1 below shows a CAIS Bus connection diagram.

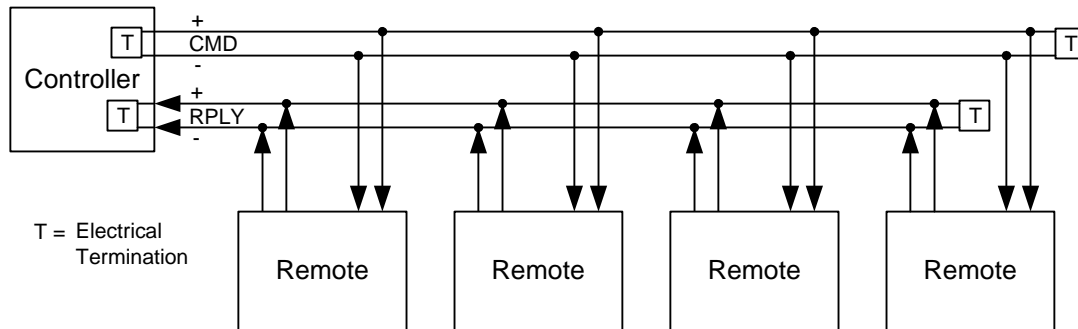

Figure 1 Typical CAIS Bus Connection

Another commonly used bus is based on EIA-485 (RS-485). Similar to the CAIS Bus, RS-485 can be used in a multi-device, multi-point configuration.

A more recently defined bus that has gained acceptance in the flight test community is the Fibre Channel Bus. Fibre Channel is a high-speed communications bus that can be implemented over a copper medium or over optical fiber. Fibre Channel can be implemented as a point-to-point bus, i.e., two endpoints connected together or as an arbitrated loop. In an arbitrated loop configuration, devices are daisy-chained together by linking the transmit output of one to the receive input of another. Each device on the bus has a unique address. Messages are transmitted onto the “loop” and pass through devices until the message reaches the intended recipient. There, messages are processed.

The diagram in Figure 2 below shows connections of Fibre Channel devices on an arbitrated loop.

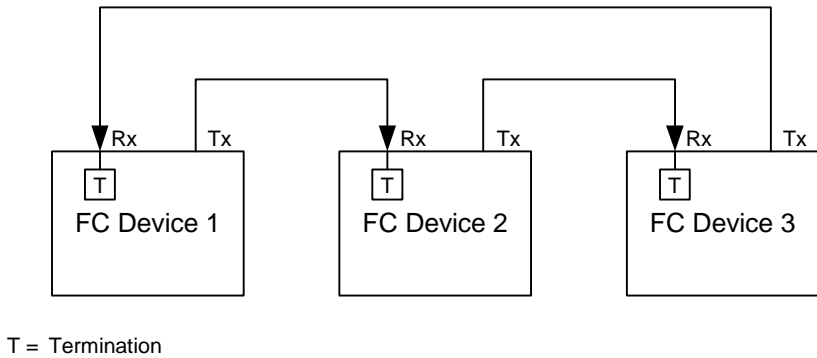

Figure 2 Fibre Channel Arbitrated Loop Configuration

CONNECTING ETHERNET NODES

Unlike the CAIS Bus or RS-485 multi-point buses, Ethernet requires point-to-point connections between devices. One reason for this is to allow for auto-negotiation between nodes. Auto-negotiation enables nodes to determine communication capabilities and to find a highest common denominator. For example, if one device is capable of 10, 100 or 1000 Mbps rates and it is connected to a device that is only capable of 10 or 100 Mbps rates, the two will negotiate to 100 Mbps operation. It should be noted, however, that the IEEE 802.3 standard defines a method whereby nodes can advertise capabilities that result in a negotiated mode of operation that is not the highest performance mode for both peer nodes.

Figure 3 below shows two 10/100Base-T network nodes connected in a point-to-point configuration.

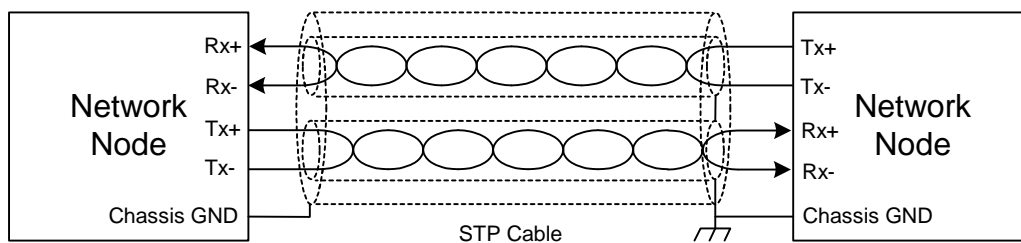

Figure 3 Network Node Connections

Over time, Ethernet networks have been constructed with different types of physical media. These media include, coaxial, Unshielded Twisted Pair (UTP), Shielded Twisted Pair (STP), and fiber optic cables. In many commercial applications, UTP cable is the cable of choice for wiring within buildings, office spaces, etc. In applications where the equipment may be subjected to harsh environments, often STP and fiber optic cabling are preferred. In addition to the environment, the type of cabling is influenced by the rate of signals being sent over the media.

Ethernet has evolved over the last 20 years to meet the increasing need for higher data rates. Although Ethernet now can support rates up to 10 gigabits per second (Gbps), the most commonly used rates of 10 and 100 megabits per second and 1 Gbps will be discussed. As the Ethernet standard has evolved, care has been taken to support backward compatibility to previous versions. When the 100 Mbps revision of Ethernet was developed (commonly known as Fast Ethernet), the standard allowed for seamless operation with 10 Mbps devices. Similarly, when 1 Gbps Ethernet was developed, the standard defined compatibility with 100 and 10 Mbps devices.

The following diagram shows the connection of various types of network nodes within a data acquisition system.

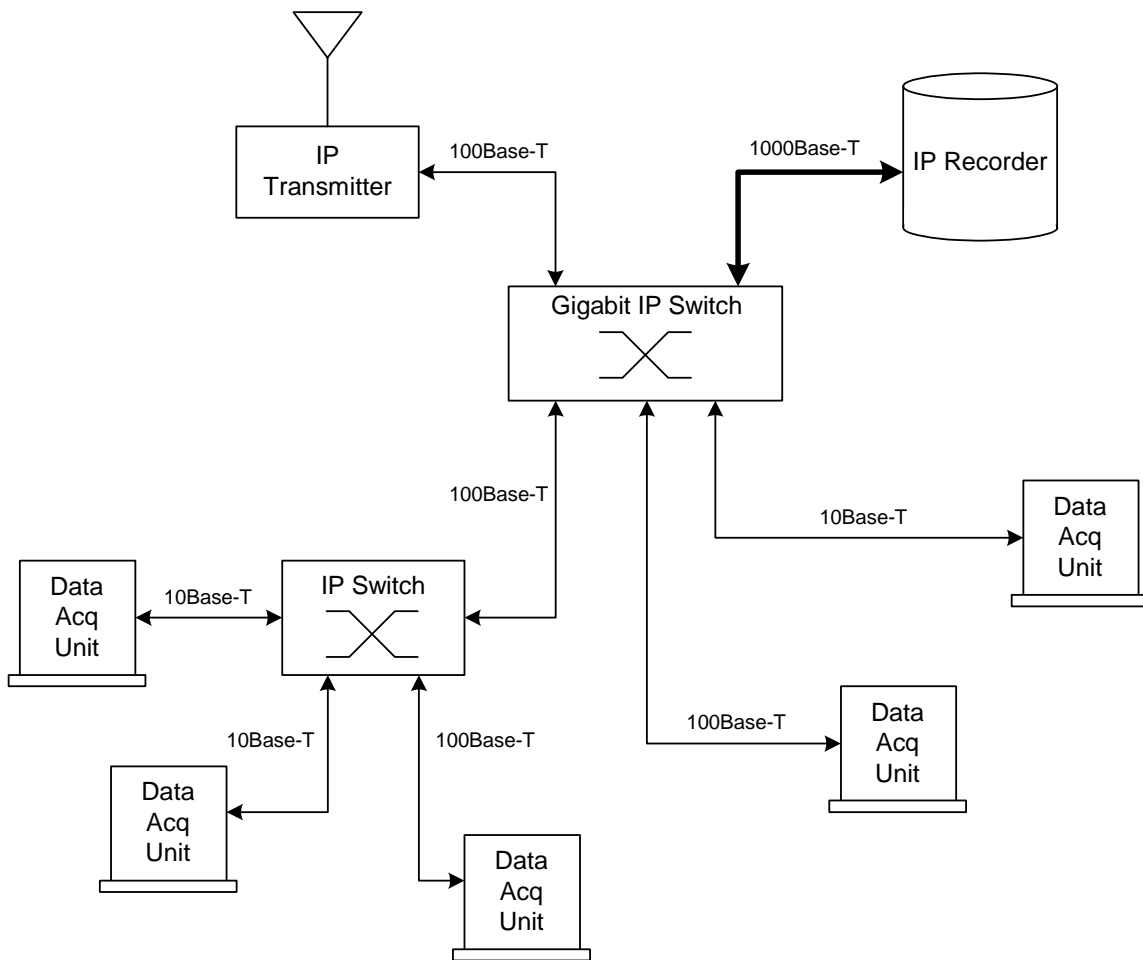

Figure 4 Network Node Connection Example

USING TWISTED PAIR CABLE

For both 10 and 100 Mbps Ethernet connections, two pairs of cable are required. One pair is used for the transmit path and the other for the receive path. In the case of Gigabit Ethernet (GbE), four pairs of cable are required. This is important to note when cabling a test article. If a physical Ethernet link is only intended to carry no more than 100 Mbps of traffic, then a two pair, four-conductor cable can be used. If, however, there is a possibility that the same cabling could carry GbE traffic in the future, it might be advantageous to install the appropriate four pair, eight-conductor cable. Unlike Fast Ethernet, GbE supports bidirectional data flow over each pair of cables.

The diagram in Figure 5 below shows the connections required for 10/100/1000 Mbps Ethernet, using twisted pair cabling.

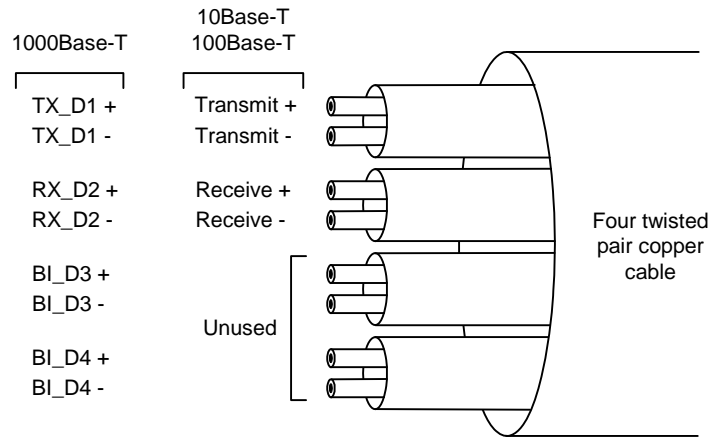

Figure 5 Connections for 10/100/1000 Mbps Ethernet

AUTO-NEGOTIATION PROCESS

Auto-negotiation allows nodes to advertise their mode(s) of operation to another node that shares the same network link segment. This is done so the nodes can configure themselves to operate at the highest level of performance common to both nodes. The auto-negotiation process occurs at power up, physical link connection and under program control.

Nodes supporting auto-negotiation use a burst of pulses, over the medium, to communicate capabilities. This burst of pulses is called the Fast Link Pulse (FLP) Burst. The pulses convey clock and data to the connected node. The data is decoded by the far-end node and used to determine the capabilities of the near-end node. The FLP Burst consists of 33 pulses. The first pulse is a clock pulse, followed by a data pulse. There are a total of 17 clock pulses and 16 data pulses in a burst. The detailed timing relationship and definition of the pulses is beyond the

scope of this paper. The reader is encouraged to refer to [1] for the specification of the FLP Burst.

Nodes that support only 10Base-T (10 Mbps) generally do not support auto-negotiation. These devices transmit link integrity test pulses. These pulses are called the Normal Link Pulse (NLP) sequence. During the auto-negotiation process, devices that respond to the FLP sequence with a NLP sequence are considered 10Base-T devices.

Figure 6 shows the general definition of the FLP Burst used to facilitate link establishment.

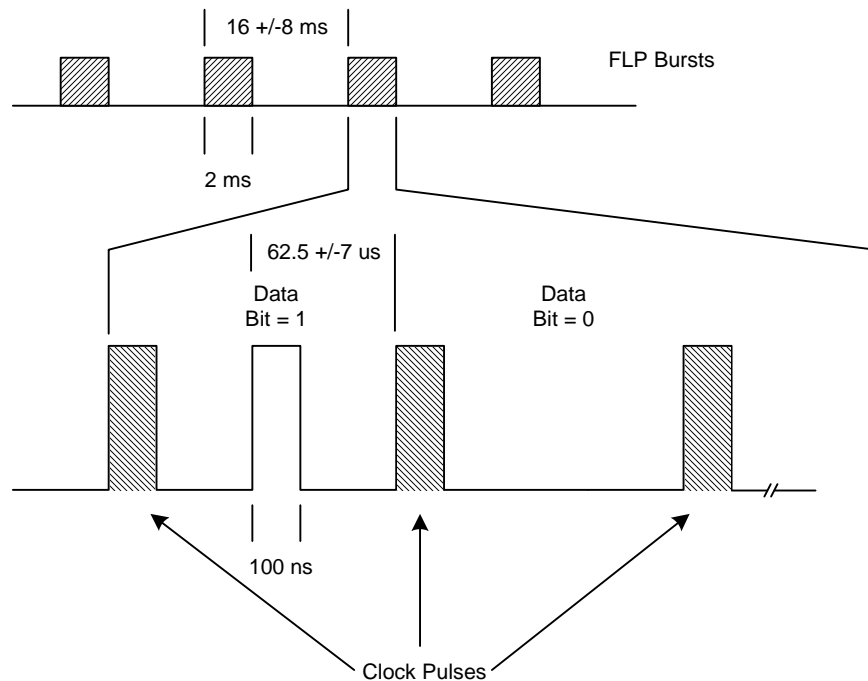

Figure 6 Fast Link Pulse Bursts

The following figures show oscilloscope screen captures of FLP pulses and bursts. A Fast Ethernet PHY device on a Teletronics OVH-350 card generated the pulses. Figure 7 below shows a FLP clock pulse and a data pulse separated by roughly 68 us .

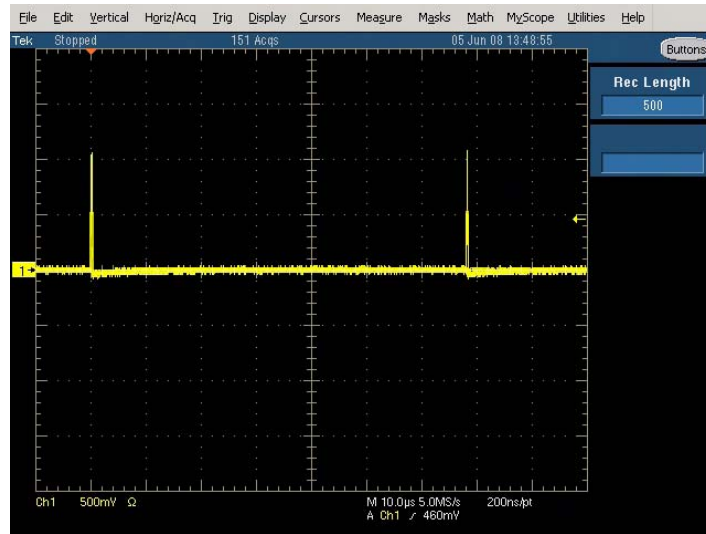

Figure 7 Two Fast Link Pulses

Figure 8 below shows several FLP bursts. The period of the bursts is about 19 ms.

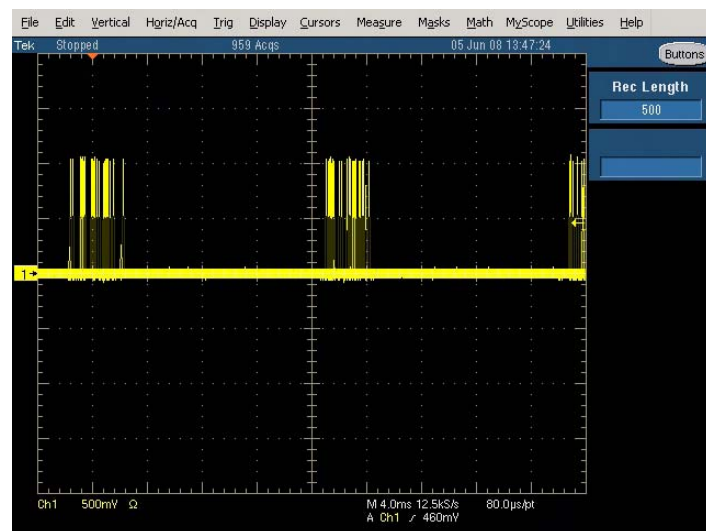

Figure 8 Several FLP Bursts

CONCLUSION

Unlike some other buses used within test instrumentation systems, an Ethernet-based network is made up of point-to-point connections, forming bus segments. As such, attempting to connect Ethernet nodes in multi-point or daisy chain type configurations would render the system unusable. Some of the benefits of a point-to-point connection scheme are as follows.

- No need for arbitration on a bus segment
- Bus segments that are congested do not necessarily affect other segments in the network
- Dedicated bus segments allow for features like auto-negotiation between peer nodes
- Bus segment failures can be isolated to minimize the impact on the rest of the network

REFERENCES

[1] ANSI INCITS 272-1996 (R2001) Fibre Channel – Arbitrated Loop (FC-AL), American National Standards Institute, April 8, 1996.

[2] IEEE Std 802.3, 2000 Edition, Part 3: Carrier sense multiple access with collision detection (CSMA/CD) access method and physical layer specifications, October 16, 2000.

[3] Berdugo, Albert A., Hildin, John J. “A System Approach to a Network Centric Airborne Data Acquisition System”, Proceedings of the International Telemetry Conference (ITC 2006), San Diego, CA USA, October 23-26, 2006.