

Airborne Wireless Network Transceiver



Description

The nXCVR 2000 Series IP transceivers are designed for air-to-ground and ground-to-air wireless OFDM-based communications. The transceivers work together to perform the function of a router, transparently interconnecting up to 32 wireless networks into a hub and spoke configuration. Bandwidth is shared among all the remote networks, each network receiving one or more timeslots for transmitting and receiving packets between itself and the hub transceiver. Timeslots are statically allocated by the user during the network configuration process.

The nXCVR-2000 Series transceivers include a 10/100/1000BASE-T Ethernet interface, multiple serial ports for external device control, a high-speed RISC processor and a power-efficient RF transmitter and receiver module. The transceivers incorporate the latest modulation and power-efficient technologies to provide maximum transmission distance under harsh environmental conditions.

The transceivers are OFDM modulation-based and have a fixed signal bandwidth of 16.5 MHz. The nXCVR-2000 Series data rate is dependent on the received RF signal power.

The 2000 Series IP transceivers exceed the IEEE 802.11a standard for processing speed, waveform compliance, and RF output power and support Simple Network Management Protocol (SNMP) for remote management.

Features

- Wireless communication for use in airborne network applications up to 100 nautical miles
- Compact, lightweight and rugged design is ideal for applications in harsh environments
- iNET compatible and exceeds expected standards for speed, power and waveform compliance
- Flexible data rates: 6 Mbps to 36 Mbps TDMA half-duplex
- Modulation format supported is 802.11a-OFDM with forward error correction
- Transmitter power of 40 W peak
- Supports IEEE 1588 time synchronization for accurate TDMA control
- Compatible with TTC network-based data acquisition and recording systems

Applications

- High speed airborne networks
- Airborne use for wireless communication with ground systems
- Ground use for wireless communication with multiple airborne test articles

nXCVR-2030B-1 Block Diagram

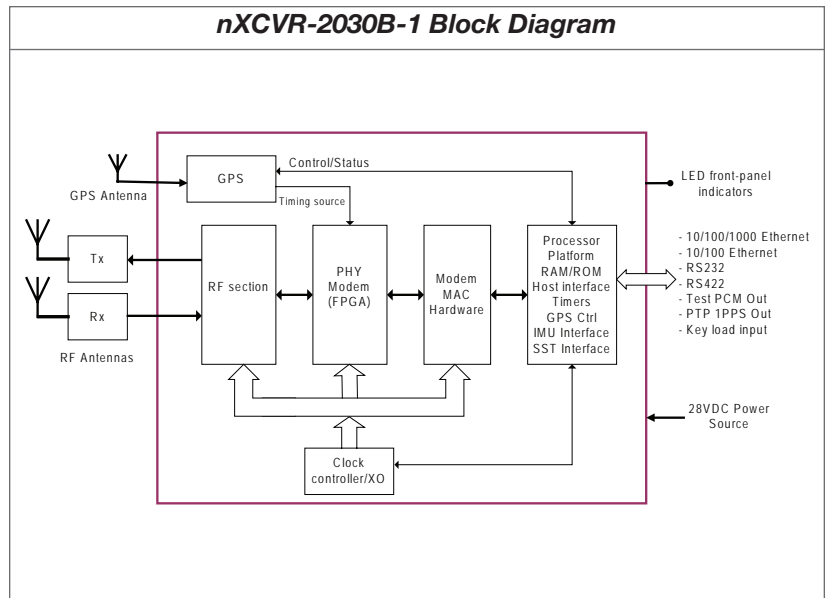

Revision 03/30/2010



Teletronics Technology Corporation
 15 Terry Drive, Newtown, PA 18940
 phone: 267.352.2020 fax: 267.352.2021 Sales@ttcdas.com

www.ttcdas.com

nXCVR-2000 Series Datasheet

©2010 Teletronics Technology Corporation
 Specifications subject to change without notice.