

# **DIVERSITY BRANCH SELECTION IN REAL WORLD APPLICATION**

**Richard Formeister**  
**Teletronics Technology Corporation**  
**RF Networks Division**

## **ABSTRACT**

Multipath propagation continues to be the dominant channel impairment in many aeronautical mobile telemetry (AMT) applications. Avoidance and diversity techniques continue to be the only practical means to combat this problem. In 2004 limited results from the development of a new post-detection, no-hit diversity selector were reported. Late breaking results from flight test were reported orally. A review of the methodology, flight test results and conclusions are presented in this paper. Also presented is an update describing enhancements of the implementation which emphasize operational flexibility as well as support for alternate demodulator products.

## **KEYWORDS**

Diversity, Aeronautical Telemetry, optimal ratio combining, selection combining

## **INTRODUCTION**

Intermediate laboratory and flight test results for a new implementation of post-detection diversity branch selection (DBS) were first reported [3] at ITC 2004 by Mr. Robert Jefferis of TYBRIN Corporation. Because of publication deadlines, further data reductions and flight test results from late May to the program conclusion could only be presented orally. Further refinements of the implementation were incorporated in late 2005 and early 2006. Final results are reviewed and the refinements are described. The DBS is pictured in Figure 1.

The prototype equipment was designed and manufactured by RF Networks, Inc. (now the RF Networks Division of Teletronics Technology Corporation) and delivered to the ARTM project in February of 2004. Reference [3] presents the important and substantial arguments for post-detection branch selection, providing an excellent background referencing the classic paper by Brennan [1] and describing the trade-offs between pre-detection and post-detection diversity strategies. Also described in [3] is the system configuration, the basic DBS functions, laboratory test configuration and the intermediate field test results. Reference [5] discusses concepts relating to post-detection diversity selection using methods similar to those reported here.

In review, the diversity branch selector selects one of two post-detection data sequences based on a quality metric of the received signal as determined by the attached demodulators. To preserve

the data sequence integrity, a correlation process performs continuous alignment without any knowledge of the sequence(s) content. Finally, clock selection is performed based on the selected source and the resulting logic tree. The quality metric, referred to as SDI (system degradation indication), is provided as a serial message at a rate of 400 to 488 per second. Further detail concerning this metric is developed in [6], while [4] describes the theory behind the pseudo-error detector. The overall objective is to achieve affordable, effective diversity performance providing new diversity possibilities and flexibility to AMT systems.

For a complete understanding of the prior results including initial flight test, the reader is encouraged to review references [3], [4] and [6].

Activity since May 2004 included additional flight testing and enhancement which allows alternate vendor demodulator implementations to match the metric requirements, as well as a wider data rate range and serial control to enhance operational flexibility. This paper summarizes and discusses the final flight test results and the enhancements to date.



Figure 1 – Diversity Branch Selector

## METHODOLOGY

Two sets of ground equipment were used in the evaluation. Flight test was conducted as established in reference [3]. Figure 2 describes the equipment used without an optimal ratio combiner (ORC), while Figure 3 describes the equipment used when comparing ORC and DBS strategies. In both cases, data was captured and recorded using a PC-based data acquisition system. The captured data consisted of the signal strength outputs (AGC1 and AGC4), BERT indication and the demodulator SDI message data. For these tests, a special decoder was devised to decode the SDI message. The decoder implementation is part hardware and part software.

## FLIGHT TEST RESULTS

Flight test continued from May, 2004 to July, 2004. Data from various flights and profiles was collected and analyzed. Limited results from data reduction were reported in [3]. The discussion which follows relates to subsets of the post-analysis data which is provided in the figures referenced below.

Figure 4 gives an indication of the multipath problem from the perspective of signal strength reported by the two demodulators. It can be seen that both constructive and destructive interference is occurring. Also, the two channels appear to be generally correlated but time shifted. This character gives good indication that branch selection as a diversity strategy will be effective. Figure 5 is reporting the SDI metric on the same flight. Again, the demodulators indicate the relative quality levels of the received signals. The segment around 60 seconds shows how the DBS should operate – the demodulator metric from the first demodulator (channel 0) reports a good signal while that of the second demodulator (channel 1) is unlocking rapidly. The DBS is expected to select channel 1.

Frequency diversity was investigated with results shown in Figure 6. In this example, it is easy to identify the presence of classic 2-ray multipath. Here is seen a comparison of no diversity (ND) versus the DBS. The DBS dramatically lowers the bit errors made in the segment. Also shown is the measurement metric “Error Free Seconds” (EFS), which helps to identify error clustering. The even distribution of EFS between ND and DBS infers little clustering occurring.

Choosing a “quiet” segment of another flight gives the results of Figure 7. The equipment used for this data was capable of including the output from an optimal ratio combiner (ORC). Then, all three data sequences are plotted. It can be seen that the ORC performance was rather dismal compared to either no diversity (ND) or the DBS. The likely reason – this flight used spatial diversity where approximately 200 feet separated the two antennas. The phase alignment requirement for ORC is violated by the antenna separation, yet the DBS acts like there is no issue at all – one of the strengths of the selector method. The effect of flight path geometry is apparent explaining why the early ORC result matches the other two but performs poorly as time progresses. As differential delay increases, the ORC performance degrades.

A second example of frequency diversity operation is presented in Figure 8. The environment was altered to a high altitude corridor, and another comparison is made of the DBS performance versus no diversity. The substantial improvement in total bit errors is easily seen, as well as the improvement in EFS.

The results from the earlier May 2004 flight tests are included. A complete reduction of data was not available for the previous paper and the results are now presented. Spatial diversity was investigated, wherein a separation of approximately 200 feet between antennas is present. Figure 9 shows an interesting phenomenon. For the first few seconds of the segment, the DBS rolls up more bit errors than the no diversity case. After this time, the DBS performs with little additional bit error while the no diversity case continues to collect bit error. The probable cause of this anomaly is fade rates greater than the DBS internal sample rate can follow, possibly also distorting the clock selection algorithm. Important to note is that as the situation clears out the DBS recovers, once again outperforming the no diversity case.

The second example from the May 2004 flight tests is shown in Figure 10. In this case, there is a large improvement factor using the DBS versus no diversity. The third example is presented in Figure 11, where again the improvement in bits recovered is demonstrated.

## ENHANCEMENTS

In May of 2006 enhancements were requested and authorized. Based on the successful flight testing, it was decided that a way to measure the SDI metric was needed to allow multiple demodulator vendors to provide the message interface, test the interface and subsequently utilize the DBS in additional systems. The measure mode was defined and added to the DBS definition. Design was then completed and added to the program prototypes. The measure mode receives and isolates the various components of the SDI message. In this mode, the DBS displays a filtered value for the interior and exterior counts, mean average deviations, plus counts of the individual message components over a one second period.

For alternate demodulator vendors, it became clear during the design that the lock signal from attached demodulators must respond within 1 to 3 milliseconds. Note that this relates to 1 to 2 SDI message times. The speed of lock is an important contributor to the performance of the DBS and was demonstrated under laboratory conditions. The DBS tolerance of fade rate depends first on the DBS internal sample rate and second on the demodulator lock times.

Two other enhancements were authorized and incorporated, namely support for lower data rates and the ability for remote control using an RS-232 interface. These enhancements were deemed necessary to improve operational flexibility.

## CONCLUSIONS

Reducing the data from Figure 8 gives the average bit error probability for the non-diversity system of  $1.4 \times 10^{-2}$ , while the DBS system yields  $6.1 \times 10^{-6}$ . Using a typical constant envelope detection performance curve, the equivalent diversity gain would be about 7 dB.

The data indicates that the performance of the DBS system is slightly short of true, hit-less switching. The ease of use was evident in both laboratory and flight testing. It has been demonstrated by field tests that the DBS approach can effectively combat multipath and masking events.

The measure mode enhancement which allows alternate demodulator vendors to provide SDI signals with the proper metric content is significant in providing support across systems with a mix of vendors. The other enhancements increase the flexibility of the approach. Using the DBS opens new possibilities to maximize the data recovered. Some of the new possibilities in deployment include antenna separation, which can be used to fill in the "hill and valley" problem, as well as provide true frequency diversity and other spatial diversity situations.

## ACKNOWLEDGEMENT

The author extends deep appreciation and acknowledgement of the considerable involvement and assistance of Mr. Robert Jefferis of TYBRIN Corporation who provided the systems engineering, arranged, tested and performed the analysis of the data presented here, as well as the ARTM Program Office.

## REFERENCES

- [1] Brennan, D. G., "Linear Diversity Combining Techniques", Proceedings of the IEEE, vol. 91, no.2, February 2003 (reprinted from the classic paper in Proceedings of the IRE, vol. 47, June 1959, pp. 1075-1102
- [2] Jefferis, R. P., "Link Availability and Bit Error Clusters in Aeronautical Telemetry", Proceedings of the International Telemetry Conference ITC/USA '99, October 25-28, 1999, Las Vegas, Nevada
- [3] Jefferis, R. P., "Telemetry Link Reliability Improvement via 'No-Hit' Diversity Branch Selection", Proceedings of the International Telemetry Conference ITC/USA '04, October 18-21, 2004, San Diego, California
- [4] Smith, David, Digital Transmission Systems, 3<sup>rd</sup> Ed., Kluwer Academic Publishers, New York New York, 2004, pp. 680-683
- [5] Osterholz, J. L., "Selective Diversity Combiner Design for Digital LOS Radio", IEEE Transactions on Communications, vol. COM-27, No. 1, January 1979, pp 229-233
- [6] Jefferis, R. P., "In-Service Detection of Multipath Fading", Proceedings of the International Telemetry Conference ITC/USA '02, October 22-24, San Diego, California, pp. 122-131

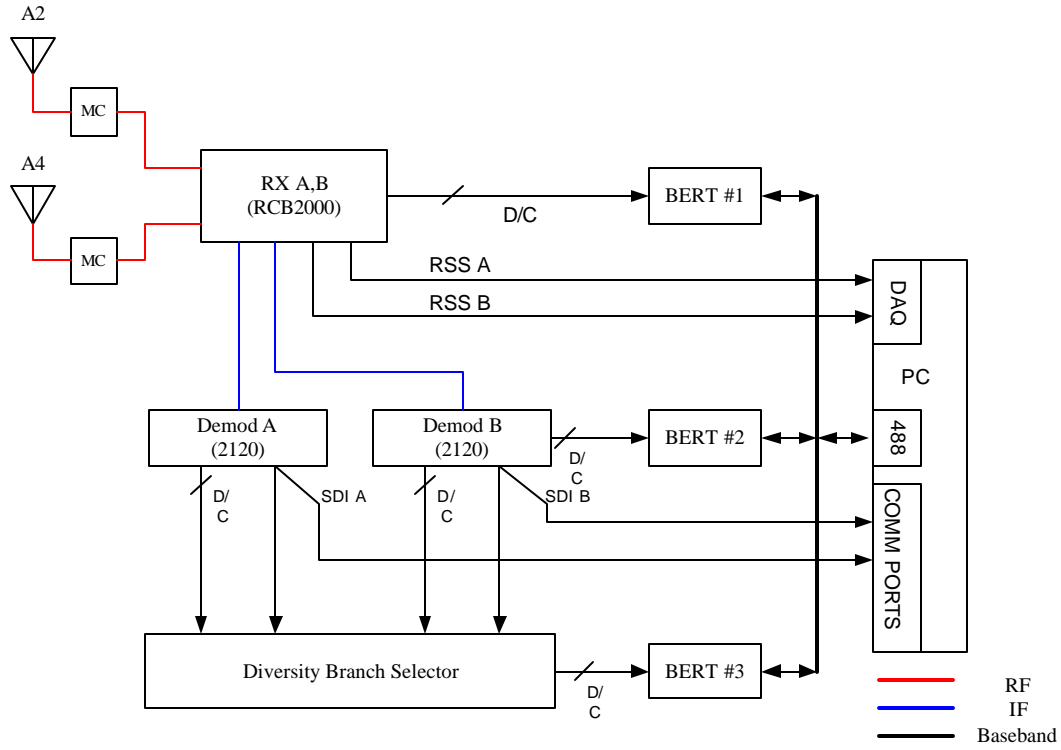

**Figure 2 – Ground Equipment, Example 1**

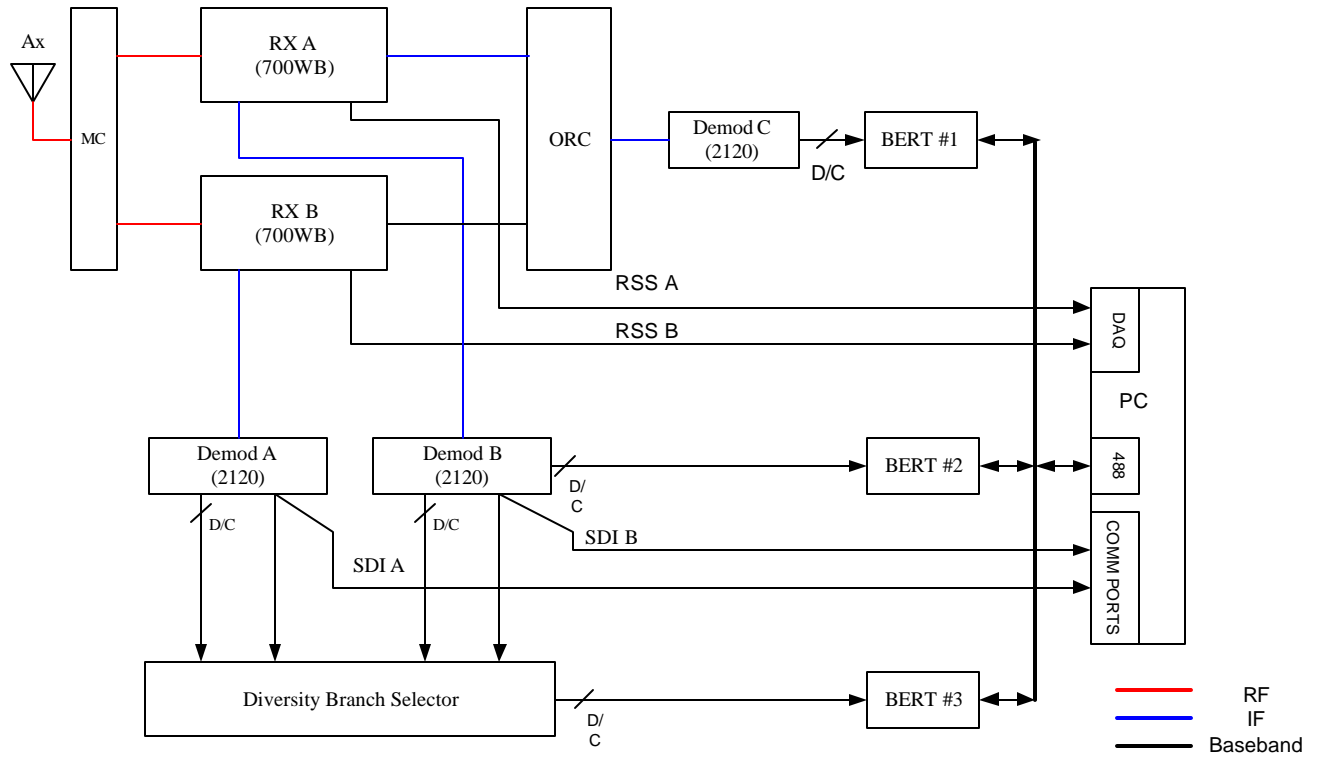

**Figure 3 – Ground Equipment, Example 2**

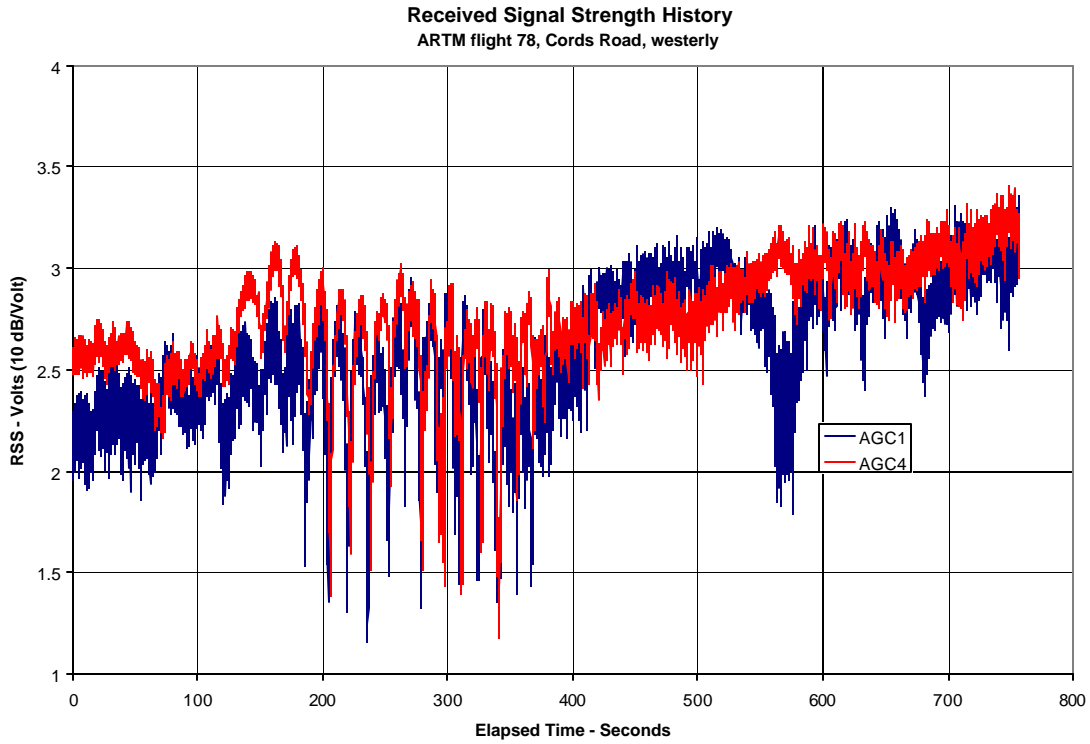

**Figure 4 – Frequency Diversity, RSS Example**

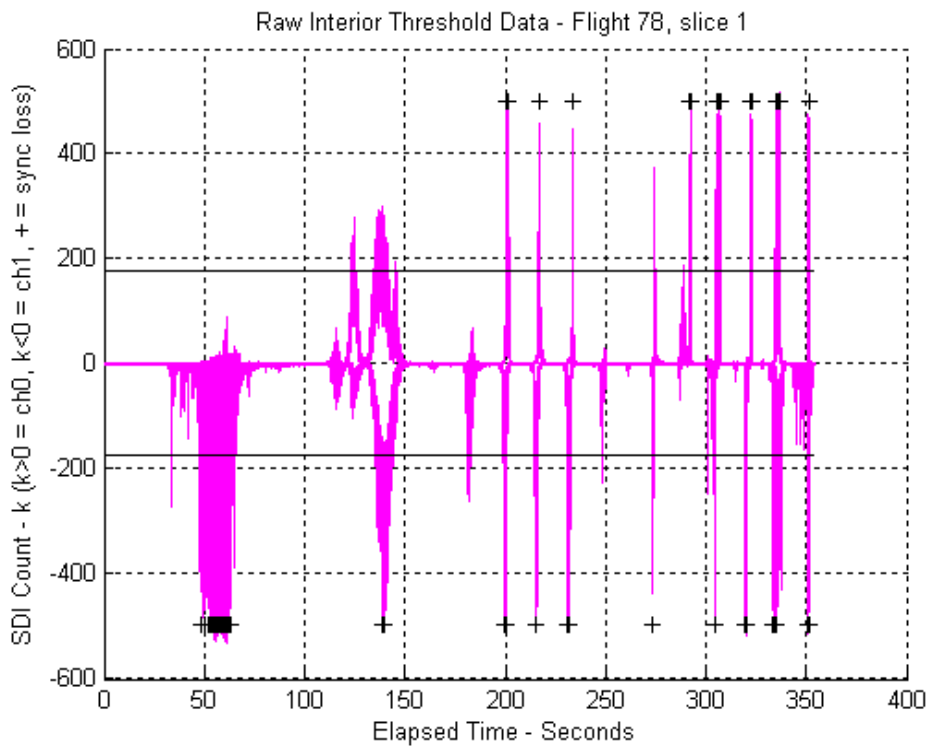

**Figure 5 – Frequency Diversity, SDI Example**

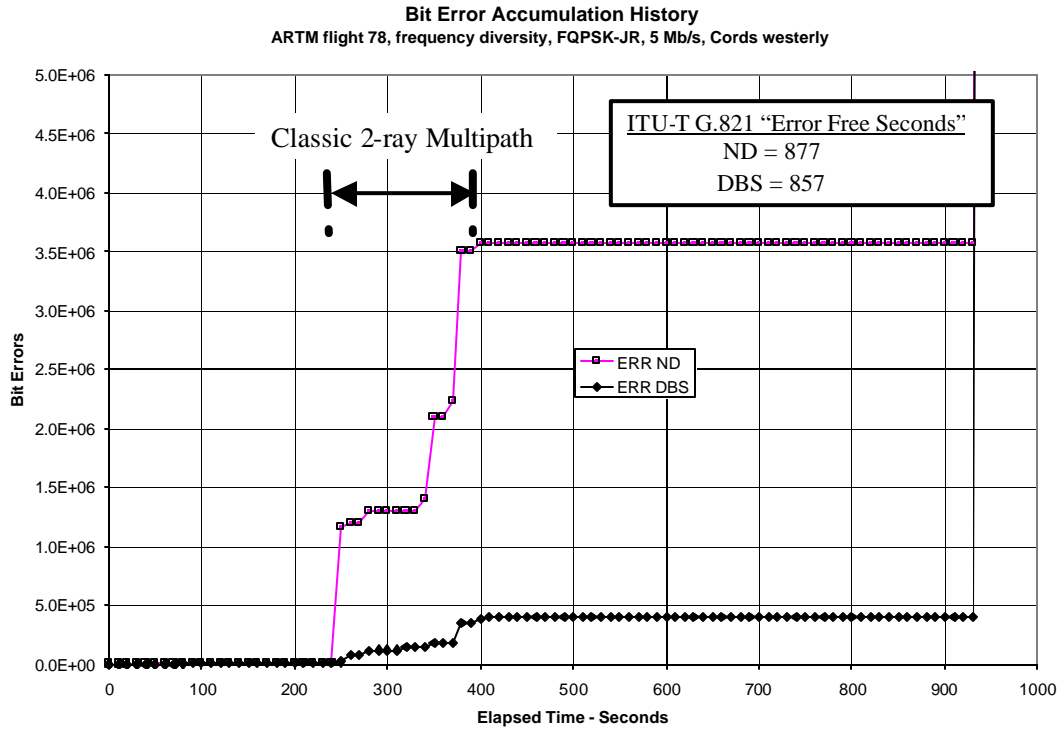

**Figure 6 – Frequency Diversity, Example 1**

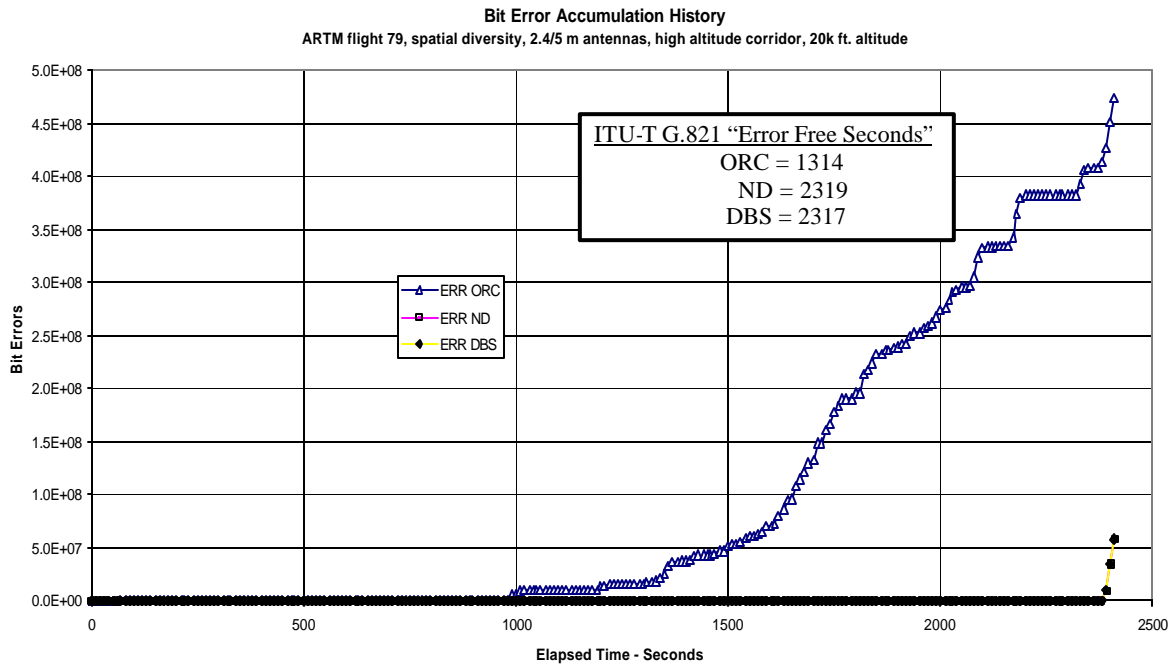

**Figure 7 – Benign Baseline Example**

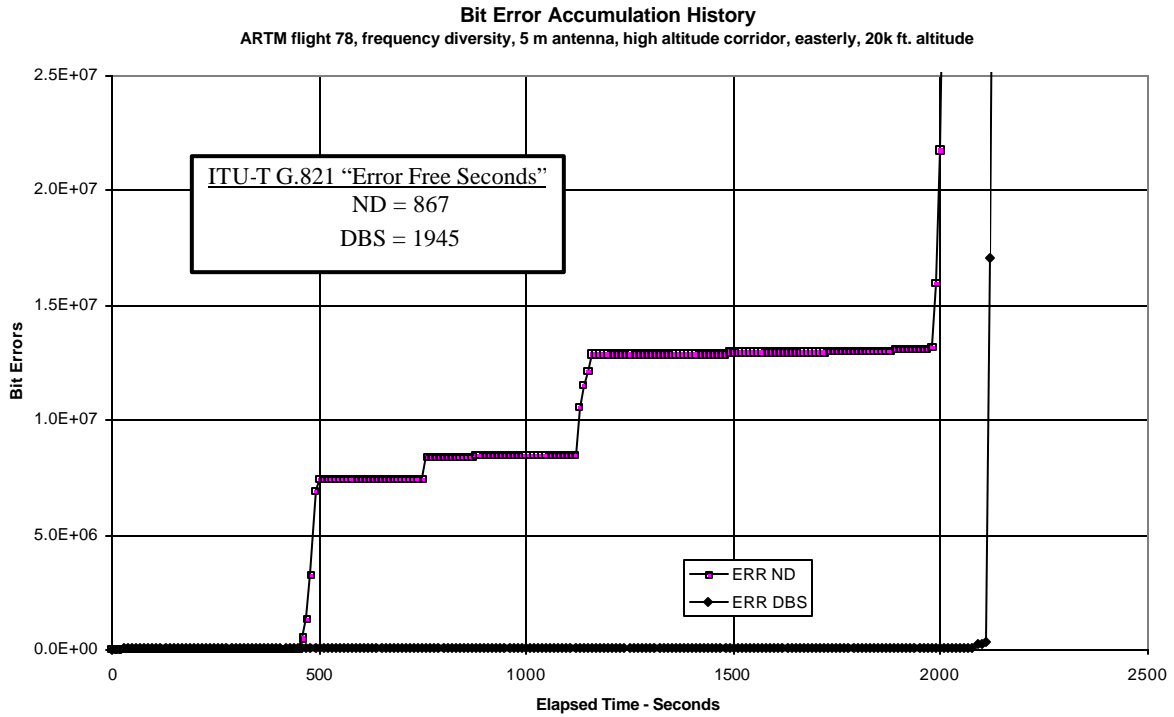

**Figure 8 – Frequency Diversity, Example 2**

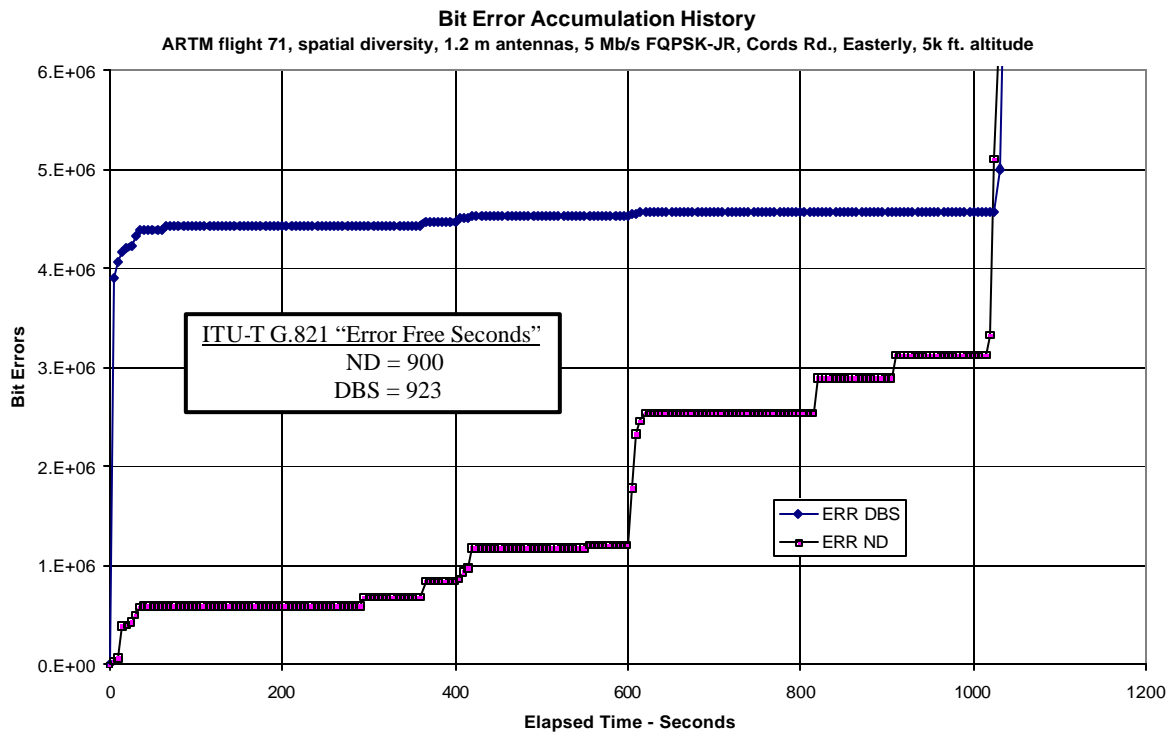

**Figure 9 – Spatial Diversity, Example 1**

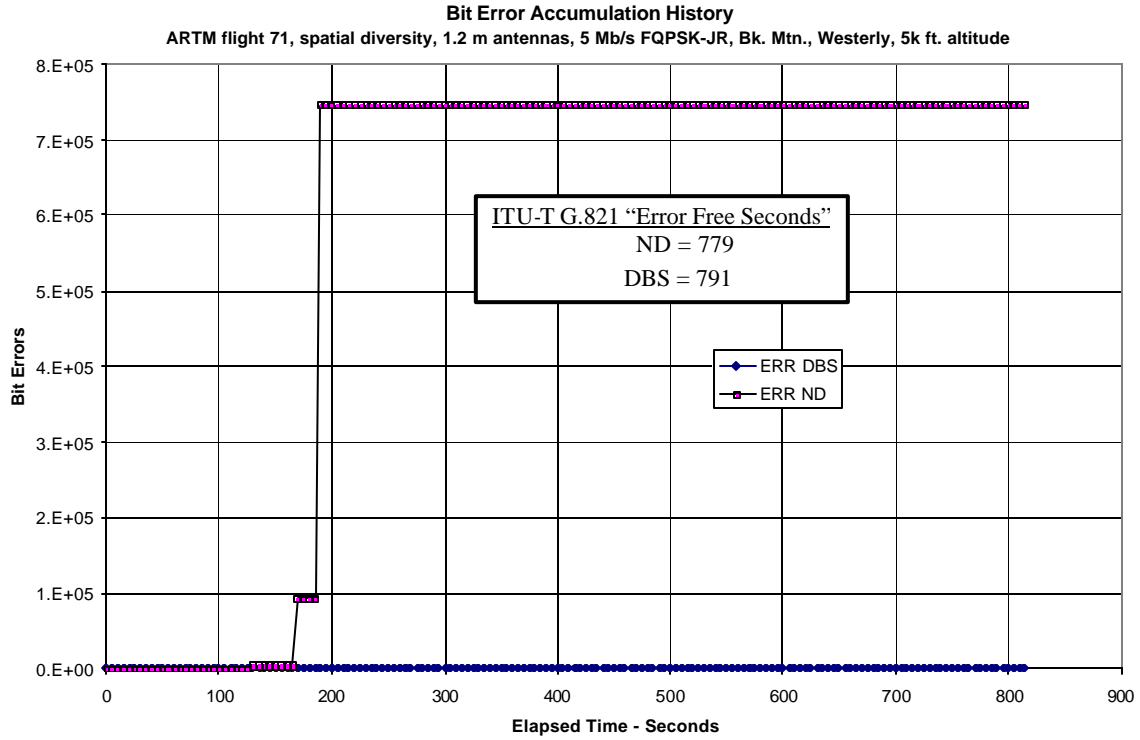

**Figure 10 – Spatial Diversity, Example 2**

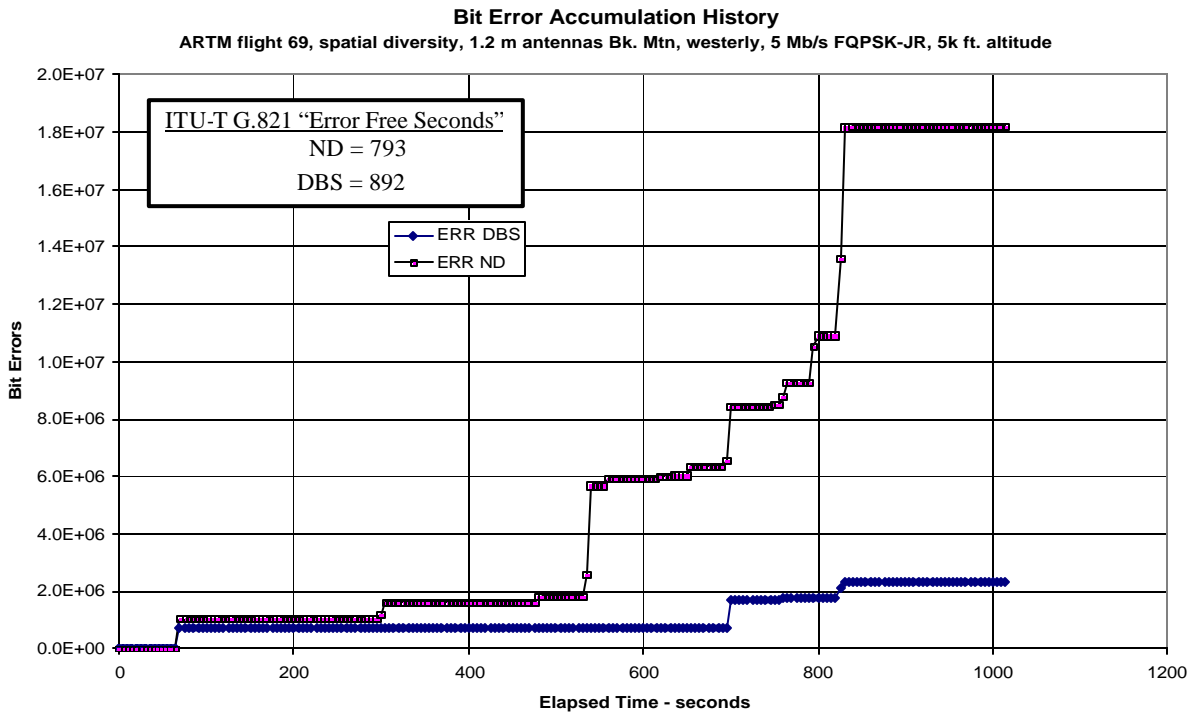

**Figure 11 – Spatial Diversity, Example 3**